



NETAJI SUBHAS OPEN UNIVERSITY
Choice Based Credit System
(CBCS)

SELF LEARNING MATERIAL

HPH
PHYSICS

CC-PH-01

Under Graduate Degree Programme

PREFACE

In a bid to standardize higher education in the country, the University Grants Commission (UGC) has introduced Choice Based Credit System (CBCS) based on five types of courses *viz. core, discipline specific, generic elective, ability and skill enhancement* for graduate students of all programmes at Honours level. This brings in the semester pattern, which finds efficacy in sync with credit system, credit transfer, comprehensive continuous assessments and a graded pattern of evaluation. The objective is to offer learners ample flexibility to choose from a wide gamut of courses, as also to provide them lateral mobility between various educational institutions in the country where they can carry their acquired credits. I am happy to note that the university has been recently accredited by National Assessment and Accreditation Council of India (NAAC) with grade ‘‘A’’.

UGC (Open and Distance Learning Programmes and Online Programmes) Regulations, 2020 have mandated compliance with CBCS for UG programmes for all the HEIs in this mode. Welcoming this paradigm shift in higher education, Netaji Subhas Open University (NSOU) has resolved to adopt CBCS from the academic session 2021-22 at the Under Graduate Degree Programme level. The present syllabus, framed in the spirit of syllabi recommended by UGC, lays due stress on all aspects envisaged in the curricular framework of the apex body on higher education. It will be imparted to learners over the six semesters of the Programme.

Self Learning Materials (SLMs) are the mainstay of Student Support Services (SSS) of an Open University. From a logistic point of view, NSOU has embarked upon CBCS presently with SLMs in English/ Bengali. Eventually, the English version SLMs will be translated into Bengali too, for the benefit of learners. As always, all of our teaching faculties contributed in this process. In addition to this we have also requisitioned the services of best academics in each domain in preparation of the new SLMs. I am sure they will be of commendable academic support. We look forward to proactive feedback from all stakeholders who will participate in the teaching-learning based on these study materials. It has been a very challenging task well executed, and I congratulate all concerned in the preparation of these SLMs.

I wish the venture a grand success.

Professor (Dr.) Subha Sankar Sarkar
Vice-Chancellor

Netaji Subhas Open University
Under Graduate Degree Programme
Choice Based Credit System ((CBCS)
Subject : Honours in Physics (HPH)
Course : Physics Laboratory - I
Code : CC - PH - 01

First Print : December, 2021

Netaji Subhas Open University
Under Graduate Degree Programme
Choice Based Credit System (CBCS)
Subject : Honours in Physics (HPH)
Course : Physics Laboratory - I
Code : CC - PH - 01

: Board of Studies :
Members

Professor Kajal De
(Chairperson)
Director, School of Sciences
NSOU

Dr. Gautam Gangopadhyay
Professor of Physics
University of Calcutta

Dr. Shib Kumar Chakraborty
Associate Professor of Physics
NSOU

Dr. Amit Kumar Chakraborty
Associate Professor of Physics,
National Institute of Technology

Dr. Gahul Amin
Assistant Professor of Physics
NSOU

Dr. Subhratanu Bhattacharya
Assistant Professor of Physics
Kalyani University

Dr Rupayan Bhattacharya
Retd . Principal, Gurudas College

Dr. Manik Sanyal
Associate Professor of Physics
Barasat Govt. College

: Course Writer :

Dr. Asok Kumar Banerjee
Retd. Associate Professor of Physics
Triveni Devi Bhalotia College

: Course Editor :

Dr. Biswajit Mukherjee
Retd. Associate Professor of Physics
Triveni Devi Bhalotia College

: Format Editor :

Dr. Gautam Kumar Mallik
Associate Professor of Physics
Netaji Subhas Open University

Notification

All rights reserved. No part of this Study material be reproduced in any form without permission in writing from Netaji Subhas Open University.

Kishore Sengupta
Registrar



**Physics Laboratory - I
Code : CC - PH - 01**

Unit - 1	<input type="checkbox"/>	Extension of spring and to find out spring constant from vertical oscillations.	7-14
Unit - 2	<input type="checkbox"/>	To find out modulus of rigidity from torsional oscillation of a wire.	15-26
Unit - 3	<input type="checkbox"/>	Determination of Moment of Inertia of a Flywheel.	27-35
Unit - 4	<input type="checkbox"/>	Determination of refractive index of a liquid by Travelling Microscope.	36-42
Unit - 5	<input type="checkbox"/>	To Find the Fourier co-efficients of different periodic vibrations by graphical method.	43-50
Unit - 6	<input type="checkbox"/>	To determine the co-efficient of viscosity of water by capillary flow method.	51-63
Unit - 7A	<input type="checkbox"/>	Determination of the acceleration due to gravity (g) using a Bar Pendulum.	64-73
Unit - 7B	<input type="checkbox"/>	Determination of the acceleration due to gravity (g) using a Kater's pendulum.	74-84
Unit - 8	<input type="checkbox"/>	Determination of thermal conductivity of a bad conductor by Less' and Chorlton's method.	85-99
Unit - 9	<input type="checkbox"/>	To determine the surface tension of a liquid by Jaeger's method.	100-112
Unit - 10A	<input type="checkbox"/>	Determination of the focal length of a concave lens by combination method.	113-121
Unit - 10B	<input type="checkbox"/>	Determination of the focal length of a convex lens by displacement method.	122-127

Unit - 11	□ To adjust a spectrometer for parallel rays by Schuster's method and to find out the angle of a prism.	128-141
Unit - 12	□ To determine an unknown low resistance using Potentiometer.	142-150
Unit - 13A	□ Write a program in C to find sum and average of given number set.	151-153
Unit - 13B	□ Write a programme in C++ to find sum and average of given number set.	154-155
Unit - 14A	□ Write a programme in C to find out largest number and its position in a given number set.	156-157
Unit - 14B	□ Write a programme in C++ to find out largest number and its position in a given number set.	158-159
Unit - 15A	□ Write a program to arrange a number in ascending order for given number set by using C.	160-161
Unit - 15B	□ Write a program to arrange a number in ascending order for given number set using C++.	162-163

Unit - 1 □ Extension of spring and to find out spring constant from vertical oscillations

Contents : Spring constant of a spring is measured considering its vertical oscillations.

Introduction :

The idea of an important parameter related to a spring, **spring constant** (K) came from Hooke's law. The spring constant is actually a measure of the stiffness of a spring. The common methods employed for measuring spring constant of a spring are statical method and dynamical method.

(A) Extension of a spring, spring constant :

It is known from Hooke's law, when an external force produces small extension or compression of a spring, the force applied or the restoring force developed in the process is directly proportional to the small extension or compression produced. The proportionality constant (K) which is the restoring force (F) per unit change in length (l) of the spring is known as spring constant (K) i.e., $k = F/l$.

Unit is N/m .

(B) Dynamical methods :

The method for measuring spring constant of a spring is known as **dynamical method** where the vertical oscillations of a loaded spring is taken into account. (Fig. 1.1). In this method, the load hanging at the end of a spring is displaced through a small distance from its equilibrium position and released. The loaded spring will execute simple harmonic motion. By measuring the time periods for different loads, we can determine the spring constant (K) of the suspended spring. Time period of oscillation is given by

$$T = 2\pi\sqrt{\frac{M+m}{K}}$$

where m = sum of masses of spring and pan

M = Mass placed on the pan.

(c) Apparatus :

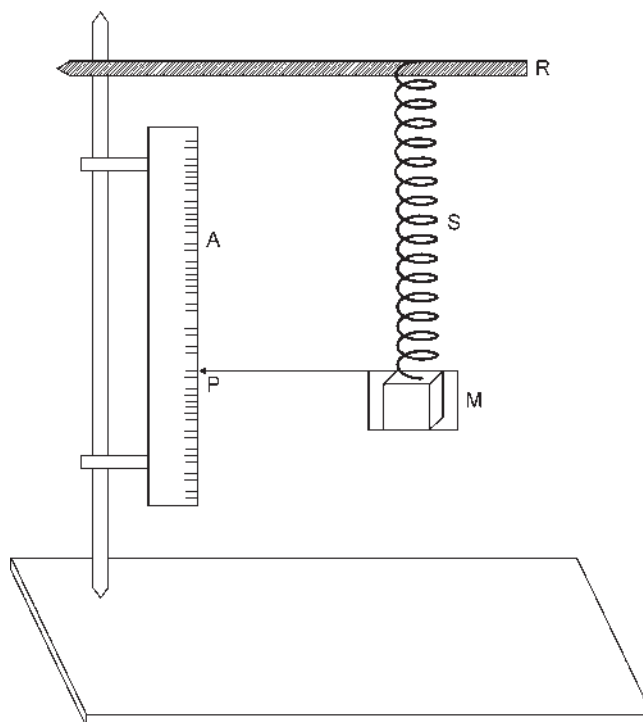

Fig. 1.1

Here, R = A rigid support.

M = Mass placed on hanger.

P = A horizontal pointer attached to pan used to measure time period of vertical oscillation.

A = A millimeter scale.

S = A spring.

Objective :

To determine the spring constant of a spring by considering its vertical oscillations.

Theory :

Definition : The restoring force developed due to unit change in length of a spring is known as its spring constant (K). SI unit of spring constant is N/m .

Working formula :

- (i) The spring constant (K) of a spring is given by

$$K \equiv \frac{4\pi^2(M_1 - M_2)}{(T_1^2 - T_2^2)} \quad \dots (1.1)$$

where, M_1, M_2 = Masses applied successively at the lower end of the spring.

T_1, T_2 = Time period for vertical oscillations of the spring corresponding to masses M_1 and M_2 respectively.

- (ii) We find,

$$T^2 = \left(\frac{4\pi^2}{K}\right)M + \left(\frac{4\pi^2}{K}\right)m, \text{ where } m = \text{mass of the spring}$$

The $M - T^2$ graph is a straight line where slope ($\tan \phi$) is $\frac{4\pi^2}{K}$.

$$\therefore K = \frac{4\pi^2}{\tan \phi} \quad \dots (1.2)$$

Procedure :

1. After placing some mass M_1 in the pan, it is displaced vertically downwards through a small distance and released.
2. The loaded spring is allowed to execute simple harmonic motion.
3. Total time required for a definite number of oscillations (say 20, 25, 30) are recorded by a stop-watch. Then time period T_1 (time for one oscillation) is calculated.
4. Now the load is increased to M_2 and following the step 3, the time period T_2 is calculated.

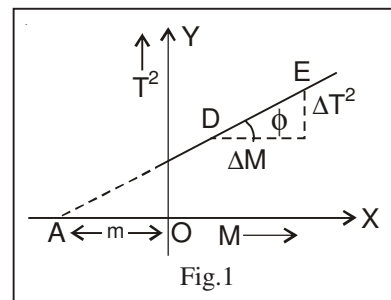

5. The experiment should be repeated with different loads.
6. A graph is now drawn with M along X -axis and corresponding T^2 along Y -axis. The graph would be a straight line (Fig.1). The slope of this straight line, $\tan \phi = \frac{4\pi^2}{K}$ and its intercept on the negative x -axis gives the mass of the spring (m).

Experimental results :**Determination of time period for different loads****Table - 1****Least count of stop watch = sec**

No. of obs.	Load in the pan (M) in gm	Number of oscillations	Total time taken in sec	Time period (T) in sec	Mean time period (T) in sec	T ² in sec ²
1.						
2.						
3.						
4.						
5.						

Calculations :**First Method :**

From equation (1.1), we know

$$K = \frac{4\pi^2 (M_1 - M_2)}{(T_1^2 - T_2^2)} = \dots\dots N/m$$

Substituting the different values of M_1 , M_2 and the corresponding values of T_1 and T_2 in the above expression, different values of K are calculated. Their mean value (K) is to be calculated.

Second Method :

The slope of the $M - T^2$ straight line graph is calculated from Fig.1

$$\text{Slope of the graph} = \tan \phi = \frac{\Delta T^2}{\Delta M} = \dots\dots\dots S^{-2}kg^{-1}$$

$$\text{Again, } \tan \phi = \frac{4\pi^2}{k}$$

$$\therefore K = \frac{4\pi^2}{\tan \phi} = \dots\dots\dots N/m$$

Result : Spring constant of the spring (K) = $\dots\dots\dots N/m$

Discussions :

1. The spring should be vertical and should oscillate vertically.
2. The amplitude of oscillation should be small, otherwise, the motion will not be simple harmonic.
3. To get the correct value of time period of oscillation, the pointer should move freely over the scale.
4. To get more accurate result (i) time period should be calculated taking higher number of oscillations. (ii) precise electronic stop-watch may be used.

Maximum Proportional error :

From equation (1.1) we get, $K = \frac{4\pi^2 (M_1 - M_2)}{(T_1^2 - T_2^2)}$

Therefore, $\frac{\delta K}{K} \Big|_{\max} = 2 \frac{\delta t}{t}$

since M is supplied and $T = \frac{\text{Total time (t)}}{\text{Number of oscillations}}$

δt = least count of stop watch, t is taken from experimental data.

Conclusion : Measured value of the spring constant (K) is accurate within the errors involved in our experimental arrangement.

Key words : (i) Loaded spring (ii) spring constant (iii) simple harmonic motion.

Summary :

- (i) Spring constant of a spring is defined and measured by considering the vertical oscillation of a loaded spring.
- (ii) The amplitude of vertical oscillation is made small to make the motion of loaded spring simple harmonic.
- (iii) For different loads placed at the end of the spring, time periods of oscillation are recorded precisely with a stop-watch having small value of least count.
- (iv) The value of spring constant (K) is calculated using equation (1.1) and also from $M - T^2$ graph.
- (v) Accuracy of measurement is checked.

Model Questions and Answers :

1. On what factors the spring constant of a spring depend ?

Ans. The spring constant of a spring depends on

- (i) the stiffness of spring material.
- (ii) the thickness of the wire from which spring is made.
- (iii) diameter of turns of coil.
- (iv) number of turns per unit length.
- (v) overall length of the spring.

2. How spring constant of a spring changes with the length of the spring?

Ans. Spring constant (K) of a spring is inversely proportional to its length.

3. Why the amplitude of vertical oscillation of spring must be small?

Ans. Consult discussion.

4. To draw graph in this experiment we use square of time period (T^2) instead of T . Why?

Ans. We know, Time period of oscillation (T) = $2\pi\sqrt{\frac{m+M}{K}}$

where, K = spring constant

M = Mass in the pan

m = mass of spring

$$\text{So, } \frac{K}{4\pi^2} \cdot T^2 = m + M$$

This shows that $M - T$ graph will be a parabola whereas $M - T^2$ graph is a straight line which can be drawn more easily.

5. Out of two methods – statical and dymical, which one is preferable to find K and why?

Ans. The statical method is more convenient than an dynamical method. This is because in statical method, we can take readings more accurately since the system is at rest, whereas, in dynamical method the accurate measurement of time period becomes difficult when motion of spring is rapid.

Unit - 2 □ To find out modulus of rigidity from torsional oscillation of a wire

Contents : Modulus of rigidity of the material of a wire is measured using torsional oscillation of the wire.

Introduction :

It is a very simple and accurate method for the measurement of the rigidity modulus of the material of a wire in the laboratory using the principle of a torsional pendulum.

Torsional Pendulum and Torsional Oscillation :

Description : The torsional pendulum is shown in Fig. 2.1. It consists of a solid cylinder (A) suspended by a long, thin experimental wire (W) of uniform cross-section. One end of the wire is rigidly fixed to a torsion head (T) and the other end is connected to the centre of the cylinder by means of detachable pin (B). The cylinder can oscillate about the suspension wire as axis. In this case, the cylinder serves as the bob of the pendulum.

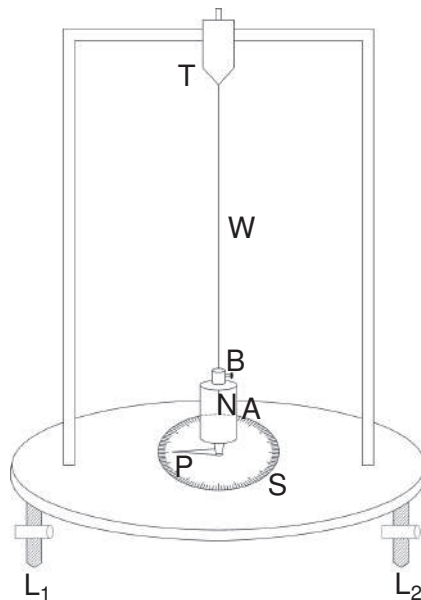

Fig. 2.1

When the suspension wire is twisted at the lower end using the cylinder, a restoring couple proportional to the angle of twist is produced. When the cylinder is released, it undergoes torsional oscillation due to the restoring couple. During torsional oscillation, a pointer (P) attached to the bottom of the cylinder moves over a circular scale (S) graduated in degrees.

Objective :

To determine the modulus of rigidity of the material of a wire from its torsional oscillation.

Theory :

Definition : Rigidity modulus is defined as the ratio of the shearing stress to shearing strain within elastic limit.

SI unit of rigidity modulus is N/m^2 .

Working formula :

The modulus of rigidity of the material of a wire is given by

$$n = \frac{8\pi l}{T^2 r^4} \dots (2.1)$$

where, r = Radius of the wire

l = Length of the wire

I = Moment of inertia of the solid cylinder attached at the end of the suspension wire.

T = Time period of torsional oscillation of the solid cylinder.

If the axis of the cylinder coincides with the axis of rotation,

$$I = \frac{1}{2}MR^2 \dots (2.2)$$

where, M = Mass of the cylinder

R = Radius of the cylinder

[using eq. (2.1) and (2.2)], the rigidity modulus of the material of a wire is

$$n = \frac{8\pi l}{T^2 r^4} \times \left(\frac{1}{2}MR^2 \right) \dots (2.3)$$

Procedure :

1. The diameter (D) of the cylinder (A) [Fig. 2.1] is measured by a slide callipers at least in five different places,. The mean diameter (D) and radius (R) of cylinder is then calculated.
2. The length (l) of the suspension wire between the torsion head (T) and the point where it is connected to the cylinder is measured by a metre scale thrice and its mean (l) is found out.
3. The diameter (d) of the suspension wire is measured by a screw gauge at five different places and their mean (d) is found out. The radius (r) of the wire is then determined.
4. Twisting the suspension wire and then an releasing it, the cylinder is allowed to execute torsional oscillation. Now with the help of a precision stop-watch, time taken by the pendulum for 15, 20, 25, 30, 35 etc. complete oscillations is noted. Time period (T) in each case is found out and their means (T) is them calculated.

Experimental results :**(A) Mass (M) of the cylinder**

$$M = \dots\dots\dots \text{ gm} = \dots\dots \text{ kg (supplied)}$$

(B) Determination of the length (l) of the suspension wire.

$$\text{Mean length } (l) = \frac{\dots\dots\dots + \dots\dots\dots + \dots\dots\dots}{3} = \dots\dots\dots \text{ cm} = \dots\dots\dots \text{ m}$$

(C) Determination of the radius (R) of the cylinder

Vernier constant (v.c) of the slide callipers

$$= \frac{\text{value of 1 smallest division of a main scale } (m)}{\text{Total number of vernier divisions } (n)}$$

$$= \dots\dots \text{ cm.}$$

$$\text{Instrument error}(e) = \pm y \times v.c$$

Table-1

No. of obs.	Reading in cm of			Instrumental error (e) in cm	Corrected diameter $D = D' - e$ in cm
	Main Scale (s)	Vernier Scale (v) = v.r × v. c	Total $R = S + V$		
1. (a)					
(b)					
2. (a)					
(b)					
3. (a)					
(b)					
4. (a)					
(b)					
5. (a)					
(b)					

N. B. : (a) and (b) denote mutually perpendicular readings at a particular place

$$\therefore D = \dots\dots \text{ cm} = \dots\dots\text{m}$$

$$\text{So, mean radius of the cylinder } (R) = \frac{D}{2} = \dots\dots\dots(m)$$

(D) Determination of the radius (r) of the wire

Screw pitch (p) = mm

Total number of circular scale divisions (N) =

$$\therefore \text{least count (l. c)} = \frac{P}{N} \dots \text{ mm}$$

$$\text{Instrumental error (e)} = \pm y \times \text{l.c} = \pm \dots \text{ mm}$$

Table-2

No. of obs.	Reading in mm of				Instrumental error (e) in mm	Corrected diameter $d = d' - e$ in mm	Mean diameter (d) in cm
	linear scale (L)	Circular Scale $C = c . r \times \text{l.c}$	Total $= L + C$	Mean diameter (d')			
1.	(a)
	(b)			
2.	(a)	
	(b)			
3.	(a)	
	(b)			
4.	(a)	
	(b)			
5.	(a)	
	(b)			

$$\therefore \text{Mean radius of the wire } (r) = \frac{d}{2} = \dots \text{ cm} = \dots \text{ m}$$

(E) Determination of time period (T)**Table-3**

No. of obs.	Number of oscillations (N)	Time for oscillations (t) in sec	Time period $(T) = \frac{t}{N}$ in sec	Mean time period (T) in sec
1.	15
2.	20	
3.	25	
4.	30	
5.	35	

Calculation :

From equation (2.3), we find the rigidity modulus of the material of the wire is

$$n = \frac{8\pi l}{T^2 r^4} \left(\frac{1}{2} MR^2 \right)$$

Substituting the values of l , M , T , r and R in the above expression, the value of n is obtained.

Result :

Rigidity modulus of the material of the wire

$$n = \dots\dots\dots \text{N/m}^2$$

Discussions :

1. The suspension wire must coincide with the axis of the cylinder.

2. As the radius (r) of the wire occurs in its fourth power and time period (T) and radius of cylinder (R) in their second power in the expression for rigidity modulus, their values should be determined very accurately.
3. The motion of the torsional pendulum should be purely rotational in horizontal plane.
4. As torsional couple is taken to be proportional to the angle of twist, the wire should not be twisted beyond elastic limit.
5. Torsional rigidity of the material of the wire can be measured with the help of this experiment.
6. Rigidity modulus (n) of the material of wire can also be determined by statical method.

Maximum proportional error :

We know from equation (2.1) and (2.2)

$$n = \frac{8\pi l}{T^2 r^4} = \frac{8\pi l}{T^2 r^4} \times \frac{1}{2} M \left(\frac{D}{2} \right)^2$$

where, $R = \frac{D}{2}$

∴ Maximum proportional error

$$= \frac{\delta n}{n} \Big|_{\max} = \frac{\delta l}{l} + \frac{2\delta t}{t} + 4 \cdot \frac{\delta r}{r} + \frac{\delta M}{M} + \frac{2\delta D}{D} \left(\because \text{Time period } (T) = \frac{t}{\text{No. of oscillations}} \right)$$

As M is large and given, $\frac{\delta M}{M}$ may be neglected.

Here, $\delta l = 0.2$ cm (2 div of metre scale),

$\delta t = 0.2 \times \dots$ s (2 divisions of stop watch)

$\delta r = \dots$ cm (*l. c.* of screw gauge)

$\delta D = \dots$ cm (*v. c.* of slide callipers)

Putting a typical set of observed data for l , r , t and D

we can calculate $\frac{\delta n}{n} |_{\max}$

\therefore Maximum percentage error $= \frac{\delta n}{n} |_{\max} \times 100\% = \dots\dots\dots\%$

Conclusion :

Measured value of the modulus of rigidity (n) of the material of the wire is accurate within the errors involved in the experimental arrangement.

Key words : (i) Modulus of rigidity (ii) Torsional pendulum and Torsional oscillation (iii) Moment of inertia (iv) Torsional rigidity (τ)

Summary :

(i) The measurement of the rigidity modulus (n) of the material of a wire by

dynamical method is discussed. Rigidity modulus is defined.

- (ii) The motion of the torsional pendulum is made purely rotational.
- (iii) To get accurate value of rigidity modulus, the radius (r) of the wire, period (T) of oscillation and radius (R) of the cylinder are measured very carefully.
- (iv) To measure time period (T) very accurately, a stop watch having small value of least count is used.
- (v) The rigidity modulus (n) of the material of the given wire is calculated by using equation. (2.1) and (2.2) with the observed value of the quantities involved.
- (vi) Accuracy of measurement is checked.

Model Questions and answers :

1. Define torsional rigidity.

Ans. Torsional rigidity (τ) is defined as the torque required to produce unit twist of

suspension wire. $\tau = \frac{n\pi r^4}{2l}$ where n , l , r bears usual meaning.

2. Does the value of rigidity modulus of the material of a wire depend on its length and diameter.

Ans. No, the value of rigidity modulus depends on the material of wire.

3. If the temperature increases, how is the rigidity modulus of a wire affected?

Ans. The rigidity modulus of a wire decreases with the increase of temperature.

4. On what factors the time period of torsional oscillation depend and how?

Ans. The time period of torsional oscillation is $T = 2\pi\sqrt{\frac{I}{\tau}}$

$$\text{or, } T = 2\pi\sqrt{\frac{2Il}{n\pi r^4}} \left(\because \tau = \frac{n\pi r^4}{2l} \right)$$

where, l , r are the length and radius of the wire respectively, n is the rigidity modulus and I is the moment of inertia of the suspended body.

Again $I = \frac{1}{2}MR^2$ (for cylinder)

$$\text{Thus } T \propto \sqrt{l}, T \propto \frac{1}{r^2}, T \propto \frac{1}{\sqrt{n}}, T \propto \sqrt{M}, T \propto R$$

So, time period increases with the increase of length of wire, mass, and radius of suspended body and decreases if diameter of wire and rigidity modulus increases.

5. On what factors the amount of twist depend?

Ans. We know, torsional rigidity (τ) = Torque per unit twist

$$\text{or, } \tau = \frac{n\pi r^4}{2l}$$

∴ The value of τ increases for higher value of rigidity modulus (n) or thicker wire (r high) and smaller length (l) of suspension wire. So greater the value of τ , smaller will be the amount of twist (θ). Therefore, θ depends on length, radius and material of the wire.

6. Is it necessary that oscillations should have small amplitude?

Ans. No, the angle of oscillation may have any value within the elastic limit of suspension wire.

7. What is the harm if the suspension wire does not coincide with the axis of the cylinder?

Ans. In this case moment of inertia of cylinder $I = \frac{1}{2}MR^2$ will not be valid. By the theorem of parallel axis, the measured moment of inertia will be higher than I by amount Md^2 where d is the distance between two axes and M is the mass of cylinder.

Unit - 3 □ Determination of Moment of Inertia of a Flywheel

Contents: Moment of inertia of a Fly-wheel about its axis of rotation is measured.

Introduction : As moment of inertia is intimately connected to the rotation of a body, its determination plays an important role to manufacture a machine producing rotational motion. A flywheel having large value of moment of inertia about its axis when connected to an engine, increases its power and ensures smooth running of the machine. So the measurement of the moment of inertia of a flywheel about its axis is very important.

Description of a Flywheel

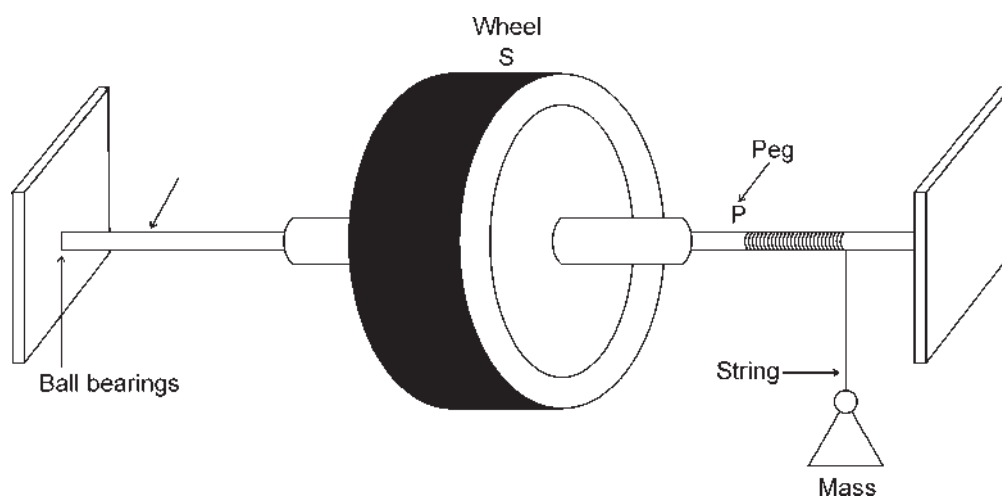

Fig. 3.1

A flywheel is a large, heavy wheel or disc S with a long cylindrical axis passing through its centre which serves as the axis of rotation. The centre of gravity ($C.G$) of the flywheel lies on the axis of rotation, so when properly mounted on ball bearings in order to minimise friction, it may remain of rest in any desired position. The horizontal axle of the flywheel is kept at a convenient height from the ground.

A tiny peg P is fixed at suitable position on the axle and a loop at the end of a piece of thin string/ thread is introduced loosely in the peg-other end of the string (thread) carries a suitable mass. Almost whole length of the string/thread is wound evenly round the axle. The length of the string/thread should be less than the height of the axle from the ground.

Objective :

To determine the moment of inertia of a flywheel about its axis of rotation.

Theory :

Definition : Moment of inertia of a body about an axis is the sum of the products of the mass of each particle in the body and the square of its distance from the axis of rotation.

SI unit of moment of inertia is Kg m^2 .

Working formula : Moment of inertia of a flywheel about its axis of rotation is given by

$$I = \frac{mgh t^2}{8\pi^2 n_2^2 \left(1 + \frac{n_1}{n_2}\right)} \dots (3.1)$$

where, m = Mass suspended from the free end of string /thread wound evenly on the axle of the flywheel.

h = Vertical height fallen through by the mass before the string leaves the axle of flywheel.

t = Time for which the flywheel continues to rotate before coming to rest after the mass gets detached from the axle of flywheel.

n_1 = Number of rotation made by the flywheel till the mass detached from the axle of flywheel.

n_2 = Number of rotation made by the flywheel in time t .

g = Acceleration due to gravity.

Procedure :

1. One end of a string or thread is tied to a known mass m and a loop is made at the other end which is fastened to a peg P fixed on the axis of flywheel (See Fig. 3.1, chapter-1).
2. The string is then wrapped completely and evenly round the axle of the flywheel until the mass m is very near to the axle. Number of turns n_1 may be 4, 6, 8 etc.
3. The vertical height h fallen through by the mass before string gets detached from the axle of flywheel is actually the length of the string wrapped since $h = 2\pi r n_1$, where r is the radius of the axle. The length of the string between the loop and the mark at the other end where the string left axle is measured by a scale which gives of the value of h .
4. Now the mass m is allowed to descend slowly under the action of gravity and the number of revolutions of flywheel n_1 during descend is noted.

5. At the very instant, the string has unwound itself and detached from the axle after n_1 turns, a stop watch is started. From this instant, the number of revolutions n_2 made by the flywheel before it comes to rest is recorded. The stopwatch is also stopped as soon as the flywheel stops. The stopwatch reading provides the value of t . Thus we get the value of n_2 and t .
6. The experiment is repeated for atleast three different masses (value of m may be 100 gm, 150 gm, 200 gm etc.)

Experimental results :

(A) Determination of n_1 , n_2 and t :

Least count of the stop watch = sec

Table-1

No. of obs.	Total load applied (m) kg	Number of revolutions of the flywheel before the mass is detached from axle (n_1)	Number of revolutions made by flywheel before it comes to rest after the mass gets detached (n_2)	Time for n_2 revolutions (t) sec.
1.				
2.				
3.				

(B) Height of fall of mass

(h) = length of string wrapped (see Procedure 3)

$$= \dots m$$

Calculations :

The moment of inertia of the flywheel about its axis of rotation is (eq. 3.1)

$$I = \frac{mgh t^2}{8\pi^2 n_2^2 \left(1 + \frac{n_1}{n_2}\right)}$$

Substituting the values of g , m , h , t , n_1 and n_2 in the above expression, we get three values of I for three different masses. The mean value of I is then calculated.

Result : The moment of inertia of the flywheel

$$I = \dots \text{ kgm}^2$$

Discussions :

1. The string should be very thin and should be evenly wound on the axle i.e., there should be no overlapping of the various coils of the string.
2. The length of string must always be less than the height of the axle of flywheel from the ground so that it may be detached from the axle before it strikes the ground.
3. The loop which is made to slip over the peg should be quite loose so that when the string has unwound itself, it must leave the axle, there should not be any tendency to rewind in the opposite direction.
4. The length of the string between the loop and the mark at the other end where string left the axle before starting of experiment gives the value of h . This length is measured by a scale.

5. To make winding to whole number of turns of string on the axle, the winding should be stopped when the projecting peg is horizontal and winding is almost complete.
6. The stop watch should be started just after the string leaves the axle.
7. There should not be any kink in the string.
8. There should be least friction in the flywheel.
9. In this experiment, the expression for I (equation 3.1) has been derived neglecting the kinetic energy $\left(\frac{1}{2}mv^2\right)$ of the falling mass m , considering large value of moment of inertia (I) of the flywheel.

If we do not follow the above simplification the expression for I becomes,

$$I = \frac{\left(\frac{mgh t^2}{8\pi^2 n_2^2} - mr^2\right)}{\left(1 + \frac{n_1}{n_2}\right)}$$

where r is the radius of the flywheel.

10. The expression for the moment of inertia of the flywheel has been derived by considering the principle of conservation of energy.

Maximum proportional error :

We find from equation (3.1)

$$I = \frac{mgh t^2}{8\pi^2 n_2^2 \left(1 + \frac{n_1}{n_2}\right)}$$

$$\text{Therefore, } \frac{\delta I}{I} |_{\max} = \frac{\delta h}{h} + 2 \cdot \frac{\delta t}{t}$$

Here, $\delta h = 2 \times$ smallest division of a metre scale

$\delta t =$ least count of stop watch,

$$\therefore \text{Maximum percentage error in } I = \frac{\delta I}{I} |_{\max} \times 100\% = \dots$$

Conclusion : Measure value of the moment of Inertia (I) of the flywheel about its axis of rotation is accurate within the errors involved in our experimental arrangement.

Key words : (i) Fly-wheel, (ii) Moment of inertia, (iii) Principle of conservation of energy

Summary :

- (i) The moment of inertia of a body about an axis is defined and the moment of inertia of a flywheel about its axis of rotation is measured, by setting it in motion with a known amount of energy.
- (ii) In measuring the moment of inertia we have used a formula which is applicable for a flywheel having high value of moment of inertia.
- (iii) Number of revolution (n_1) of the flywheel before the mass gets detached from the axle is measured carefully.
- (iv) The number of revolutions (n_2) of the flywheel before it comes to rest after the mass is detached is also carefully measured.

- (v) Moment of inertia of the flywheel is calculated using equation (3.1)
- (vi) Possible sources of error and precautions to be taken are discussed.
- (vii) Accuracy of measurement is checked.

Model Questions answers

1. Does the moment of inertia of a body depend on its axis of rotation?

Ans. Yes. Moment of inertia of a body depends on the axis of rotation since moment of inertia of a body about an axis is the sum of the products of the mass of each particle in the body and the square of its distance from the axis

of rotation *i.e.* $I = \sum_i m_i r_i^2$.

2. Can you perform your experiment with a load of any mass?

Ans. No. The mass of the load must be sufficient to overcome friction and cause the wheel to rotate without external help.

3. Would you require long or short height of fall?

Ans. To make n_2 and t large, a bit longer height of fall is required because it will cause w of high value.

4. Which quantity should be measured accurately in this experiment?

Ans. As the time (t) for which the flywheel rotates after the mass gets detached from the axle occurs in the second power in the expression for I , it should be measured with higher accuracy.

5. Why the string used should be very thin?

Ans. The string should be very thin so that its radius is very small in comparison to the radius is very small in comparison to the radius of the axle otherwise,

its radius should be added to that of the axle to get r . The radius (r) of the axle should be measured carefully if we employ the formula $I = \left(\frac{m}{n_1 + n_2} \right)$

$\times \left(\frac{ght^2}{8I^2 n_2} - r^2 n_2 \right)$ to measure moment of inertia.

Unit - 4 □ Determination of refractive index of a liquid by Travelling Microscope

Contents : The refractive index of a liquid is measured following the idea of Snell's law of the refraction of light.

Introduction :

There are different methods for the determination of refractive index of a liquid. The simplest method of measurement of refractive index of a liquid is the mechanical method such as using a travelling microscope. In this case, the refractive index of a liquid is measured by considering the relation between real depth and apparent depth of the liquid.

Objective :

To determine the refractive index of a liquid using a travelling microscope.

Theory :

Definition : The refractive index (μ) of a medium may be defined as the ratio of the velocity of light (c) of a given wavelength in vacuum to the velocity of light (v) in that medium i.e. $\mu = \frac{c}{v}$.

Refractive index has no unit.

Working formula :

The refractive index of a liquid is given by

$$\mu = \frac{\text{Real depth of the liquid}}{\text{Apparent depth of the liquid}}$$

$$\mu = \frac{u}{v} \quad \dots (4.1)$$

$$\mu = \frac{R_3 - R_1}{R_3 - R_2}$$

where, R_1 = Microscope reading for the cross mark (made on the inner bottom of a beaker) when the beaker is empty,

R_2 = Microscope reading for the image of cross mark when beaker contains some amount of experimental liquid.

R_3 = Microscope reading for the liquid surface.

Procedure :

1. The microscope tube is fixed vertical and the eye piece is distinctly focussed on the cross-wires.
2. The vernier constant of the vertical scale of the travelling microscope is determined.
3. Making a cross-mark on the inner bottom of an empty glass beaker, the cross-mark is sharply focussed by the microscope avoiding parallax. Main scale and vernier scale readings are taken. Three sets of readings are taken and their mean value (R_1) is calculated.
4. Now, taking some amount of experimental liquid in the beaker, the image of the cross-mark is sharply focussed by the microscope avoiding parallax. Main scale and vernier scale readings are taken. Repeating the process thrice, three sets of readings are taken and their mean value (R_2) is found out,

5. Then a small quantity of the lycopodium powder or cork dust is spread on the liquid surface and the microscope is sharply focussed on the powder without any parallax. After repeating the process thrice, three sets of readings are recorded. The mean of these three readings (R_3) is calculated.
6. Thus, the real depth of the liquid = $u = R_3 - R_1$ and the apparent depth of the liquid = $v = R_3 - R_2$.

From this data, the refractive index (μ) of the given liquid is determined by using eq.(4.1)

7. The whole process is repeated for two other depths of the liquid and refractive index (μ) for each depth is determined. The mean of these three values will give the correct value of μ .

Experimental results :

(A) Readings for the cross-mark when the beaker is empty

Verrier constant (v.c) of the vertical scale of the travelling microscope

$$= \frac{\text{value of 1 smallest division of main scale}}{\text{Total number of vernier divisions}}$$

$$= \frac{S}{n} = \dots\dots\dots \text{cm}$$

Table-1

No. of obs.	Main scale reading (s) cm	Vernier scale reading (V) = (v.r × v.c) cm	Total reading $R_1 = (S + V)$ cm	Mean reading (R_1) cm
1.				
2.				
3.				

(B) Readings for the image of the cross-mark and for the liquid surface.

Table-2

Liquid depth	No. of obs.	Reading for the image of cross mark				Reading for the liquid surface				Depth of liquid	
		Main Scale (S) cm	Vernier Scale (v) = (v. r × v.c) cm	Total = R ₂ = (S+V) cm	Mean (R ₂) cm	Main Scale (S) cm	Vernier Scale (V) = (v. r × v.c) cm	Total = R ₃ = (S+V) cm	Mean R ₃ cm	Real depth (u) = R ₃ -R ₁ cm	Apparent depth (v) = R ₃ - R ₂ cm
Small	1										
	2										
	3										
Medium	1										
	2										
	3										
Large	1										
	2										
	3										

Calculations :

The refractive index of the liquid (μ) = $\frac{u}{v}$

For three different liquid depths, the refractive index of liquid μ_1, μ_2, μ_3 are determined by using the above relation.

Result : Experimental value of the refractive index of the given liquid

$$\mu = \frac{\mu_1 + \mu_2 + \mu_3}{3} = \dots\dots\dots$$

Discussions :

1. The axis of the microscope should be vertical.
2. The lycopodium powder or cock dusk shuld be sprinkled over the liquid surface very thinly.
3. Parallax between the image and the cross-wire should be avoided.
4. Liquid depth should not exceed the focal length of the objective of the microscope.
5. To help the focussing process, a piece of white paper should be kept below the beaker.

Maximum proportional error :

Refractive index $\mu = \frac{u}{v}$

Therefore, $\frac{\delta\mu}{\mu} |_{\max} = \frac{\delta u}{u} + \frac{\delta v}{v}$

Here $\delta u = \delta v = 2 \times v$. c of the microsope. u. v are taken from the data obtained.

So, maximum percentage error $= \frac{\delta\mu}{\mu} |_{\max} \times 100\% = \dots\dots\%$

Conclusion : The calculated value of refractive index is accurate within the error involved in our experimental arrangement.

Key Words : (i) Refractive index (ii) Travelling microscope (ii) Parallax.

Summary :

- (i) Refractive index of a medium is defined.
- (ii) The determination of refractive index of a liquid by measuring the real and apparent depth using a travelling microscope is discussed.
- (iii) The real depth and apparent depth of the liquid are measured avoiding parallax between the image and cross-wire.
- (iv) Accuracy of the measurement is checked.

Model questions and answers :**1. Does the refractive index of a substance depend on the colour of light?**

Ans. Yes. Refractive index of a substance is high for light having smaller wavelengths and low for light having higher wavelengths.

So, Refractive index of a substance for violet light (μ_v) > Refractive index of the substance for red light (μ_r)

since $\lambda_{\text{violet}} < \lambda_{\text{red}}$

2. Is this method suitable for a volatile liquid?

Ans. No. If the liquid is volatile, it will evaporate quickly and depth of liquid will change during experiment.

3. Can any depth of liquid be taken?

Ans. No. The depth of liquid taken should not exceed the focal length of the objective of travelling microscope.

4. What happens if the cross-mark is given on the outer surface of the bottom of the beaker?

Ans. When cross-mark is made on the outer surface of the bottom of beaker, the thickness of the beaker comes into play and thus real depth of liquid is not obtained.

5. Does the accuracy of result depend on the depth of liquid taken?

Ans. Yes, greater depth gives more accurate result with less percentage error but it should not exceed the focal length of the objective of telescope.

6. Can you apply this method for a transparent solid?

Ans. Yes. If the solid is taken in the form of a plate or block, its refractive index can be found out by a travelling microscope following same process.

Unit-5 □ To Find the Fourier co-efficients of different periodic vibrations by graphical method.

In this exercise, we shall find the Fourier co-efficients of a periodic function depicted in a graph.

Definition : Any periodic function can be represented as the sum of an infinite series of cosine and sine functions with proper co-efficients. These co-efficients are called Fourier co-efficients.

Theory : Any periodic function can be expressed as a series of cosine and sine functions.

$$f(x) = \frac{a_0}{2} + \sum_{n=-\infty}^{\infty} \left[a_n \cos\left(\frac{2\pi nx}{L}\right) + b_n \sin\left(\frac{2\pi nx}{L}\right) \right]$$

L is the periodicity of the function $a_0, a_1, a_2, \dots, b_1, b_2, \dots, a_{-1}, a_{-2}, \dots, b_{-1}, b_{-2}, \dots$ are the Fourier co-efficients. The co-efficients can be expressed as

$$a_0 = \frac{2}{L} \int_{-L/2}^{L/2} f(x) dx$$

$$a_n = \frac{2}{L} \int_{-L/2}^{L/2} f(x) \cos\left(\frac{2\pi nx}{L}\right) dx$$

$$b_n = \frac{2}{L} \int_{-L/2}^{L/2} f(x) \sin\left(\frac{2\pi nx}{L}\right) dx$$

Example : Figure 1 below shows a piece-wise continuous function.

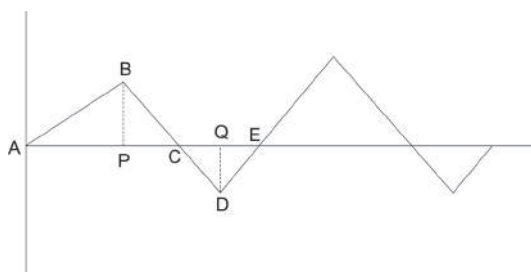

Fig. 1 : A periodic function

ABCDE is a periodic function ; $AE = L$ is the period. Figure 1 shows two periods. ABCDE consist of four points ; AB, BC, CD, DE. Each part can be represented by a function like $f(x) = p + qx$. Each part has different values of p, q .

Let $x = 0$ at A ; at B, $x = x_1$, at C, $x = x_2$; at D, $x = x_3$; at E, $x = L$.

$$a_0 = \frac{2}{L} \left[\int_0^{x_1} (p_1 + q_1x) dx + \int_{x_1}^{x_2} (p_2 + q_2x) dx + \int_{x_2}^{x_3} (p_3 + q_3x) dx + \int_{x_3}^L (p_4 + q_4x) dx \right]$$

$$a_1 = \frac{2}{L} \left[\int_0^{x_1} (p_1 + q_1x) \cos(2\pi x/L) dx + \int_{x_1}^{x_2} (p_2 + q_2x) \cos(2\pi x/L) dx \right. \\ \left. + \int_{x_2}^{x_3} (p_3 + q_3x) \cos(2\pi x/L) dx + \int_{x_3}^L (p_4 + q_4x) \cos(2\pi x/L) dx \right]$$

$$a_2 = \frac{2}{L} \left[\int_0^{x_1} (p_1 + q_1x) \cos(4\pi x/L) dx + \int_{x_1}^{x_2} (p_2 + q_2x) \cos(4\pi x/L) dx \right. \\ \left. + \int_{x_2}^{x_3} (p_3 + q_3x) \cos(4\pi x/L) dx + \int_{x_3}^L (p_4 + q_4x) \cos(4\pi x/L) dx \right]$$

$$b_1 = \frac{2}{L} \left[\int_0^{x_1} (p_1 + q_1x) \sin(2\pi x/L) dx + \int_{x_1}^{x_2} (p_2 + q_2x) \sin(2\pi x/L) dx \right. \\ \left. + \int_{x_2}^{x_3} (p_3 + q_3x) \sin(2\pi x/L) dx + \int_{x_3}^L (p_4 + q_4x) \sin(2\pi x/L) dx \right]$$

and so on.

EXPERIMENT :

In figure 2, a graph represents a periodic function.

Graph of a symmetric periodic function

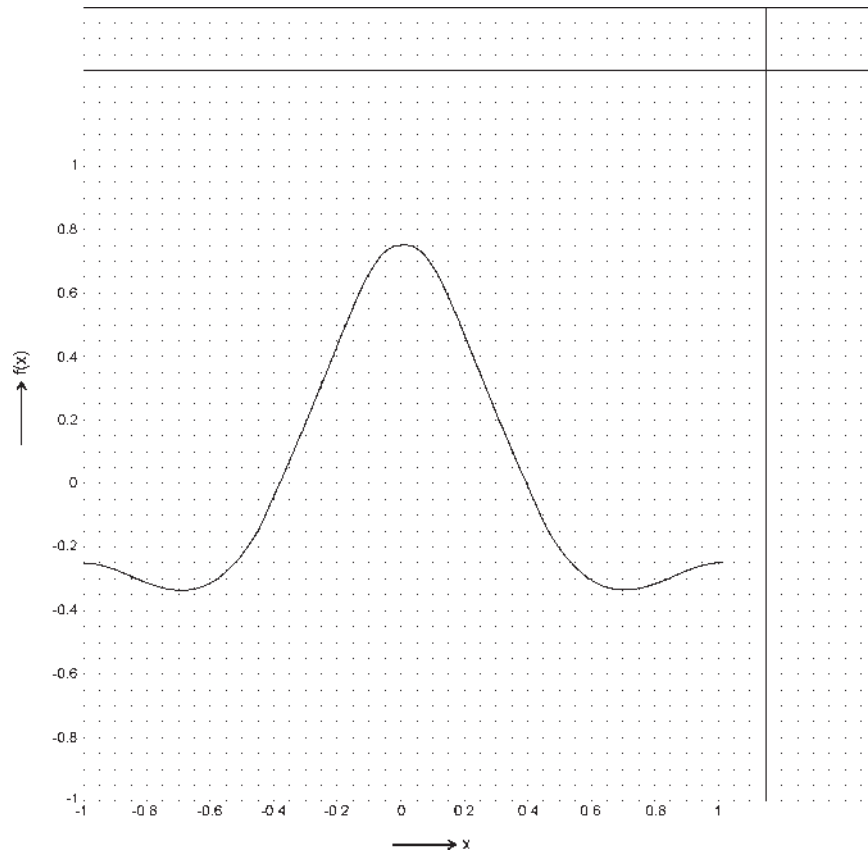

Figure 2 : A periodic function drawn on a graph

The function is symmetric around $x = 0$; period length is 2 units. A symmetric function will have only cosine components. So, we have to find a_1, a_2, \dots

Value of x ranges from -1 to $+1$, So the period $L = 2$. This range is divided into $N = 40$ divisions. Value of each segment is $\Delta x = L/N = 0.05$. At each point, value of x can be given by $x_i = i \Delta x$; $i = 0$ at the centre. i goes from -1 to $-N/2$ towards left edge and it goes from 1 to $N/2$ towards right from centre.

Since the function is symmetric, only one half is sufficient for calculation. We make a table with x_i values and $f(x_i)$ values at each x_i found from the graph taking only the right half.

Table 1Values of $f(x_i)$ and its product with $\cos(2\pi nx_i/2)$ for $n = 1, 2, 3$

i	x_i	$f(x_i)$	$f(x_i) \cos(\pi x_i)$	$f(x_i) \cos(2\pi x_i)$	$f(x_i) \cos(3\pi x_i)$
0	0	0.750	0.750	0.694	0.7500
1	0.05	0.730	0.721	0.546	0.6504
2	0.10	0.675	0.642	0.353	0.3968
3	0.15	0.600	0.535	0.148	0.0939
4	0.20	0.480	0.388	0.000	- 0.1483
5	0.25	0.375	0.265	- 0.068	- 0.2652
6	0.30	0.220	0.129	- 0.059	- 0.2092
7	0.35	0.100	0.045	0.040	- 0.0988
8	0.40	- 0.05	- 0.015	0.143	0.0405
9	0.45	- 0.15	- 0.023	0.250	0.0681
10	0.50	- 0.25	- 0.000	0.304	0.0000
11	0.55	- 0.32	0.050	0.291	- 0.1453
12	0.60	- 0.36	0.111	0.220	- 0.2912
13	0.65	- 0.375	0.170	0.113	- 0. 3704
14	0.70	- 0.365	0.215	0.000	- 0.3471
15	0.75	- 0.35	0.247	- 0.100	- 0.2475
16	0.80	-0.325	0.263	- 0. 176	- 0.1004
17	0.85	- 0.30	0.267	- 0.222	0.0469
18	0.9	- 0.275	0.262	- 0.250	0.1616
19	0.95	- 0.26	0.257	0.247	0.2317
20	1.00	- 0.25	0.250	0.750	0.2500
	Total	0.3	5.529	2.73	0.4664

Calculation :

$$a_0 = \frac{2}{L} \int_{-L/2}^{L/2} f(x) dx = \frac{2}{L} 2 \int_{-0}^{L/2} f(x) dx$$

The factor $2/L = 1$ because $L = 2$. The integration will be replaced by summation for discrete x and $f(x)$ values.

$$a_0 = 2 \sum_{i=1}^{21} f(x_i) \Delta x$$

$\Delta x = 0.05$; from the table $\sum_{i=0}^{20} f(x_i) = 0.3$. So, $a_0 = 0.03$

$$\text{Similarly, } a_1 = 2 \sum_{i=0}^{20} f(x_i) \cos(2\pi x_i / 2) \Delta x$$

$$= 0.1 * \sum_{i=0}^{20} f(x_i) \cos(2\pi x_i / 2) = 0.1 * 5.5290 = 0.5529$$

$$a_2 = 2 \sum_{i=0}^{20} f(x_i) \cos(4\pi x_i / 2) \Delta x = 0.1 * \sum_{i=0}^{20} f(x_i) \cos(4\pi x_i / 2) = 0.1 * 2.73 = 0.273$$

$$a_3 = 2 \sum_{i=0}^{20} f(x_i) \cos(6\pi x_i / 2) \Delta x = 0.1 * \sum_{i=0}^{20} f(x_i) \cos(6\pi x_i / 2) = 0.1 * 0.4664 = 0.0466$$

Actual values are $a_0 = 0$; $a_1 = 0.5$; $a_2 = 0.25$; $a_3 = 0$.

SOURCES OF ERROR :

There are basically two sources of error. Firstly, the values of each $f(x_i)$ measured from graph differs from true value due to eye-estimation. Secondly, the integration in the Fourier co-efficient expressions represents the area within the curve and x-axis. When the integration is replaced by a summation of discrete values, the area is replaced as a sum of rectangular areas. If the length of each segment Δx decreases, it converges to the actual area under the curve.

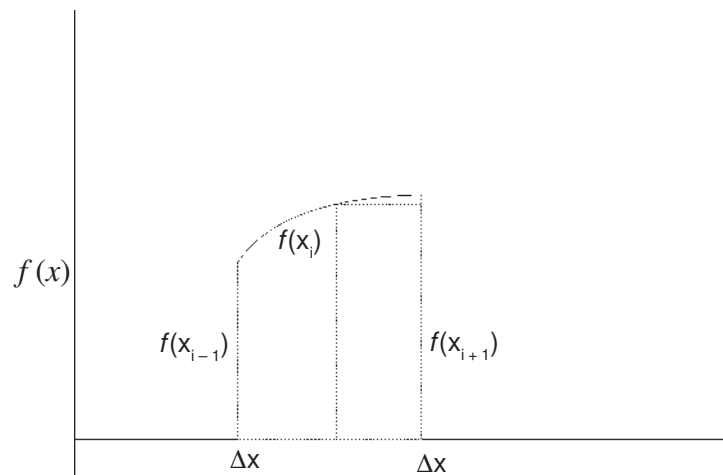
**DISCUSSION :**

We discuss briefly the importance of Fourier co-efficients. In many situations, physical quantities are periodic but discontinuous or piecewise discontinuous or rapidly varying. An example is the potential/electric permittivity distribution in a solid state/photonic crystal. To extract physical properties, one has to solve second order differential equation like Schrödinger equation or Helmholtz equation. Functions of above mentioned type are hard to incorporate in such equations. Fourier theorem help transform these functions into a series of continuous functions. Although the series is infinite, practically a finite number of terms are sufficient. So, one has to know the Fourier co-efficients to transform approximately a discontinuous function into a continuous function.

EXERCISES :

Find the Fourier coefficients of the curves shown in the following graphs.

(i) Graph of a anti-symmetric periodic function

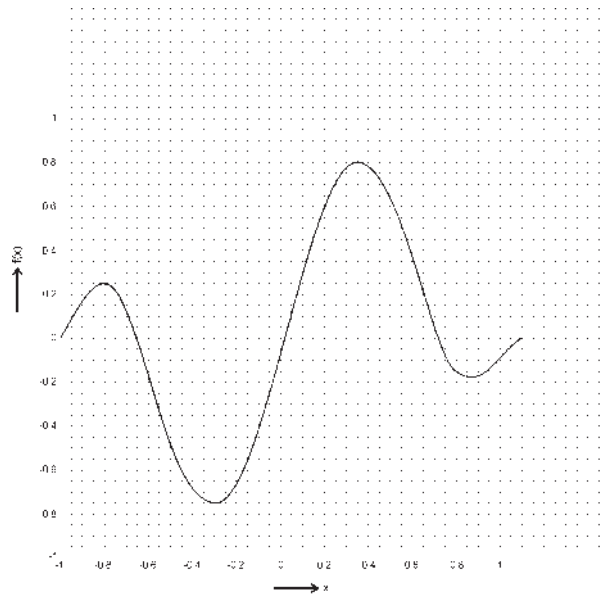

Answer : $b_1 = 0.4$; $b_2 = 0.5$

(ii) Graph of a mixed periodic function

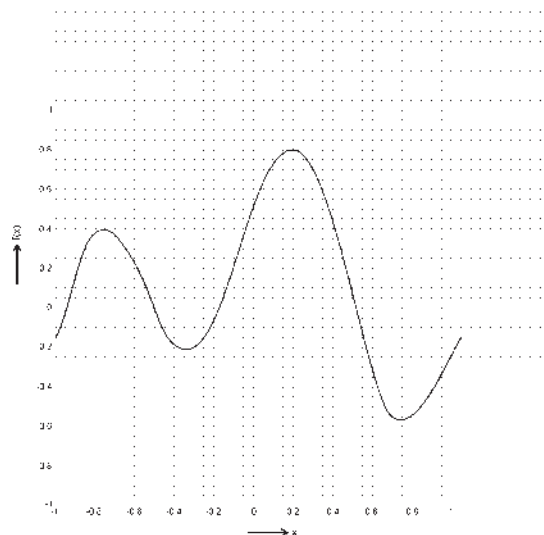

Answer : $a_0 = 0.1$; $a_1 = 0.25$; $b_1 = 0.5$

Find the Fourier co-efficients ($a_{-2}, a_{-1}, b_{-2}, b_{-1}, a_2, a_1, a_2, b_1, b_2$) functions analytically and graphically of following :

(iii)

Graph of a square periodic function

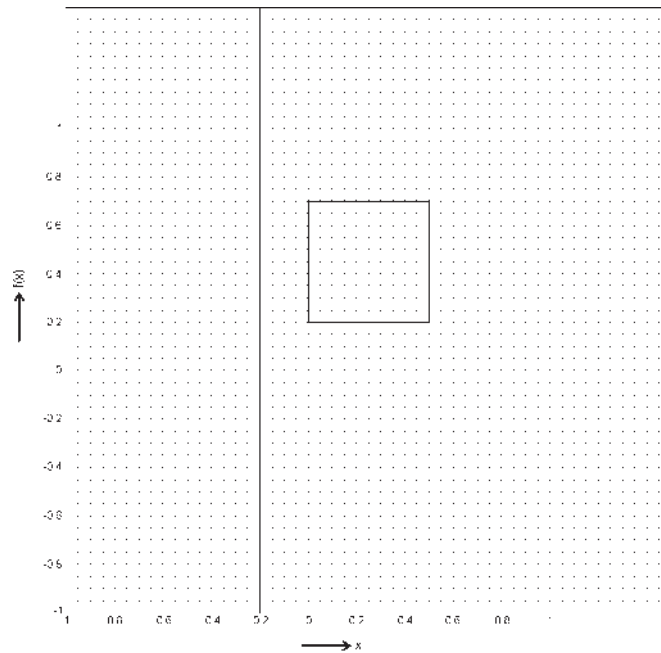

(iv)

Graph of a triangular periodic function

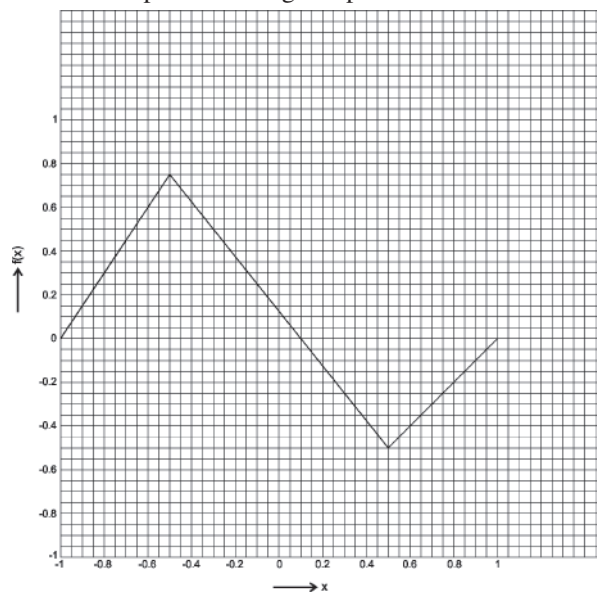

Unit-6 □ To determine the co-efficient of viscosity of water by capillary flow method

Contents : The co-efficient of viscosity of water is measured by Poiseuille's method.

Introduction : Viscosity is the general property of every fluid which acts only when fluids are in motion. Due to this property of fluid, resistance is developed against gradual deformation of a fluid by shear stress or tensile stress. At the molecular level, viscosity may be interpreted as the result of interaction between different molecules of a fluid. The measurement of the co-efficient of viscosity of water by considering its streamline flow through a capillary tube is one of the accurate methods used in the laboratory.

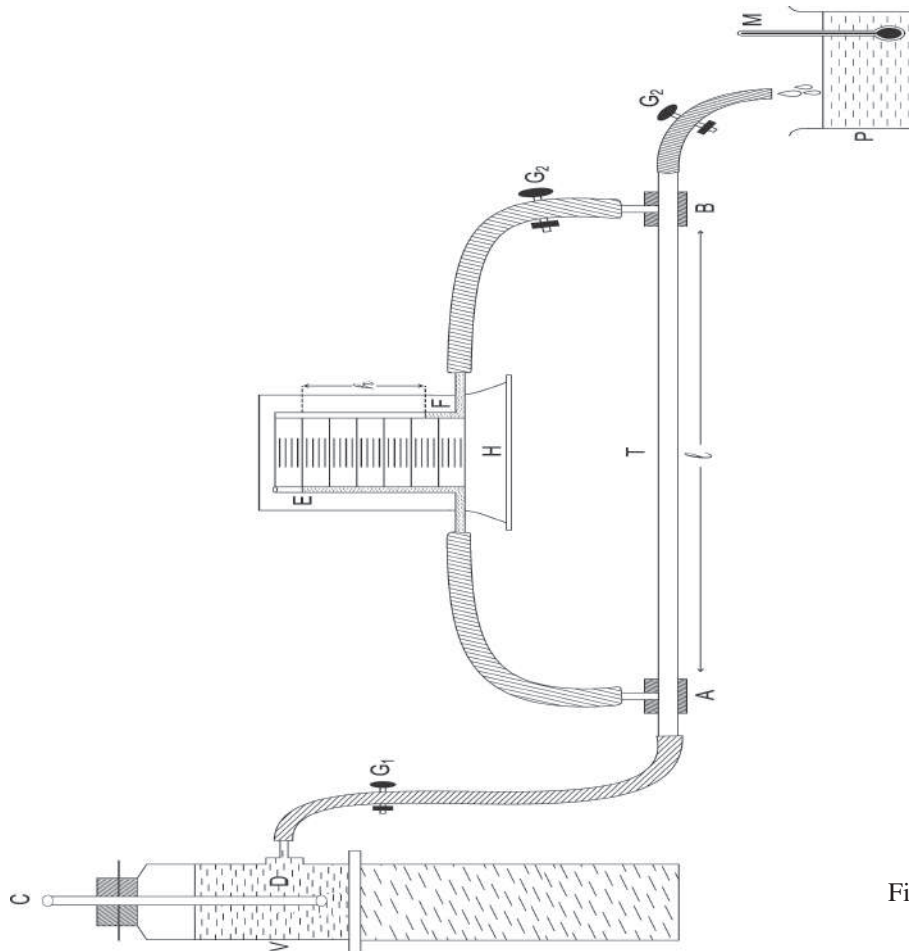

Fig. 6.1

Description :

- T → A horizontal capillary tube which is inserted into two small brass chambers A and B .
- V → Water reservoir connected to chamber A through the pinch-cock G_1 .
- E and F → Two limbs of a manometer H connected to chambers A and B respectively. The manometer is provided with a scale to measure difference (h) of water level in the two limbs of manometer.
- G_2 → Pinch-cocks provided with the entrance and exit tube of chamber B .
- CD → A glass tube open at both ends inserted in the water reservoir V .
- M → A thermometer used to measure temperature of water stored in the beaker P .

Objective : We intend to measure the co-efficient of viscosity of water using its streamline flow through a capillary tube.

Theory :

Definition : The co-efficient of viscosity of a fluid (water) is defined as the tangential stress acting on any one of the two adjacent fluid (water) surfaces when there is unit velocity gradient between them.

SI unit of co-efficient of viscosity is $\text{N} \cdot \text{s}/\text{m}^2 = \text{Poiseulle (Pl)}$

Working formula :

The co-efficient of viscosity of water is given by

$$\eta = \frac{\pi Pr^4}{8lV} \dots (6.1)$$

where, l = length of a uniform capillary tube.

r = Internal radius of the capillary tube.

P = Pressure difference under which water flows in streamlines through the horizontal capillary tube.

V = volume of water flowing out per second.

The pressure difference (P) is given by

$$P = h\rho g \dots (6.2)$$

where, h = Height of water column producing pressure difference P

ρ = Density of water.

g = Acceleration due to gravity.

$$\text{Therefore, } \eta = \frac{\pi r^4 (h\rho g)}{8lV} \dots (6.3)$$

Procedure :

1. After cleaning the capillary tube T (Fig. 6.1) its length (l) is measured by a metre scale thrice and its mean (l) is determined.

2. To determine the internal radius (r) of the capillary tube and r^2 , r^4 the steps given below are to be followed.

(a) Introducing a long pellet of mercury in the capillary tube, the length (L) of the pellet is measured at different positions of the tube by a travelling microscope.

(b) The mercury column is then taken in a crucible of known mass and the mass (m) of the mercury column is measured. The the square of internal radius

(r^2) of the tube, $r^2 = \frac{m}{\pi L \rho'}$ is calculated where ρ' is the density of mercury at room temperature.

3. By adjusting the pinch-cock G_1 (sometimes G_2) (Fig 4.1 of chap-1, unit-4), steady and small difference in the height (h) of water level in the two limbs of the manometer H is maintained such that water flows to the beaker in very slow stream. Then pressure difference (P) under which water flows is $P = h\rho g$ where ρ is the density of water at room temperature, h is measured by the scale attached to the manometer. Noting the temperature of water in the beaker by a thermometer, ρ is found out from a table.

4. Now, the volume of water (V') is collected in a measuring cylinder (preferably having lowest graduation 0.1 ml or 0.5 ml) for a given time (t), time is measured by a stop-watch.

Hence, the volume of water flowing out through the tube per second, $(V) = \frac{V'}{t}$ is determined.

5. The experiment is repeated for atleast five different values of h and the corresponding values of rate of flow of water (V) is measured.

6. Then, a graph is plotted with h along x -axis and rate of flow of water (V) along

y-axis. The graph will be a straight line passing through the origin (Fig.1). By choosing a point (A) on the graph, its coordinate (h , v) is found out.

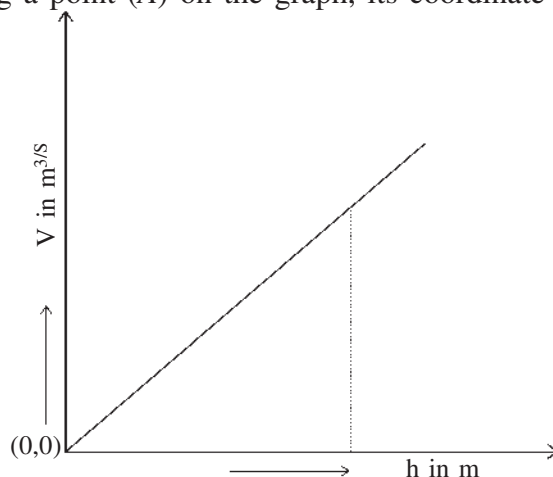

Fig. 1

Experimental results :

(A) Determination of length (l) of the capillary tube by a metre scale.

Table-1

No. of obs	Measured length (l) cm	Mean length (l) (cm)	length (l) (m)
1.			
2.			
3.			

(B) Determination of the length (L) of the mercury column in the capillary tube by using a travelling microscope.

Vernier constant of the microscope (v.c) = cm

Table-2

Position of mercury column	Reading for the left end of mercury column			Reading for the right end of mercury column			Length of mercury column $L = R_1 \sim R_2$ (cm)	Mean L (cm)	L (m)
	Main scale (S) (cm)	Vernier scale (V) ($= v.r \times v.c$) (cm)	Total $R_1 (= S + V)$ (cm)	Main scale (S) cm	Vernier scale $V (= v.r \times v.c)$ (cm)	Total R_2 ($= S + V$) (cm)			
1.									
2.									
3.									

(C) Determination of radius (r) and r^4 of the capillary tube :

Table-3

Room temperature (T) =°C

Density of mercury at room temp (ρ') = kg/m³ (from table)

Mean length (L) of the mercury column (From table-2) (m)	Mass of the crucible		Mass of mercury column $= m = m_2 - m_1$ (gm)	$r^2 = \frac{m}{\pi L \rho'}$ (cm ²)	r^2 (m ²)	r^4 (m ⁴)
	When empty (m_1) (gm)	When with mercury (m_2) (gm)				

(D) Determination of pressure difference (P) in terms of h.**Table-4**

No. of Obs.	Reading of the water level in the left arm of the manometer = R_1 (cm)	Reading of the water level in the right arm of the monometer = R_2 (cm)	Height of water level $h = R_1 - R_2$ (cm)	Height h (m)
1.				
2.				
3.				
4.				
5.				

(E) Determination of the rate of flow (V) of water by measuring cylinder**Table-5**

No. of Obs.	Height of water level (h) (cm) [From table-4]	Time of collection of water (t) (sec)	Volume of Water collected (V') (cm ³)	Mean Value of (V') (cm ³)	Volume of water collected per sec $V = \frac{V'}{t} \times 10^{-6}$ (m ³ /s)
1.
2.
3.
4.
5.

Calculations :

From eq. (6.3), we find the coefficient of viscosity of water

$$\eta = \frac{\pi r^4 (h\rho g)}{8lV}$$

- (i) Measuring room temperature, we can find density of water (P) at that temperature from the table.
- (ii) Plotting $h - V$ graph (Fig.1), we can find out h and V choosing a point on this straight line graph.
- (iii) Substituting the value of r, h, l, V, ρ, g in the above expression for η , we obtain the value of η .

Result :

The co-efficient of viscosity of water at room temperature ($\dots^\circ\text{C}$) is

$$\eta = \dots\dots\dots \text{N.S/m}^2 = \dots\dots Pl$$

Discussions :

1. The capillary tube should be uniform. The radius (r) should be measured very accurately as it occurs in the fourth power in the expression of η .
2. The pressure difference (P) should be small, otherwise the flow of water through capillary tube will not be streamlined but turbulent, h should be less than $\frac{h_c}{2}$, where h_c is the critical height (given).

3. To improve accuracy of the result, sufficient quantity of water must be collected in the measuring cylinder.
4. As η changes with temperature, the temperature of water should be noted carefully.
5. As capillary tube is horizontal, water coming out from open end may run back. To eliminate this, little grease or vaseline should be kept at the open end.

Maximum proportional error :

The co-efficient of viscosity of water

$$\eta = \frac{\pi Pr^4}{8lV} = \frac{\pi r^4 (h\rho g)t}{8lV'} \quad \left[\because V = \frac{V'}{t} \right]$$

Therefore, the maximum proportional error

$$\frac{\delta\eta}{\eta} \Big|_{\max} = \frac{4\delta r}{r} + \frac{\delta h}{h} + \frac{\delta t}{t} + \frac{\delta l}{l} + \frac{\delta V'}{V'} \quad (\because \rho \text{ and } g \text{ are supplied})$$

$$\text{As, } r^2 = \frac{m}{\pi L\rho},$$

$$\frac{2\delta r}{r} \Big|_{\max} = \frac{\delta m}{m} + \frac{\delta L}{L}$$

$$\text{Hence, } \frac{\delta\eta}{\eta} \Big|_{\max} = 2\frac{\delta m}{m} + \frac{2\delta L}{L} + \frac{\delta h}{h} + \frac{\delta t}{t} + \frac{\delta l}{l} + \frac{\delta V'}{V'}$$

Knowing the maximum values of possible errors in the measurement of h , m , L , t , l , V' .

we can determine $\frac{\delta\eta}{\eta} \Big|_{\max}$

$$\therefore \text{Maximum percentage error} = \frac{\delta\eta}{\eta} |_{\max} \times 100\% = \dots\dots \%$$

Conclusion : Measured value of the co-efficient of viscosity of water is accurate within the errors involved in the experimental arrangement.

Key words : (i) Co-efficient of viscosity (ii) streamline and turbulent motion. (iii) critical height (iv) critical velocity.

Summary :

- (i) The co-efficient of viscosity is defined. The measurement of the co-efficient of viscosity of water by using Poiseuille's equation is discussed.
- (ii) The streamline flow of water through the capillary tube is maintained by keeping small pressure difference across its ends.
- (iii) To calculate the rate of flow of water (V) through the tube accurately, a measuring cylinder with very small graduations is used.
- (iv) The straight line portion of ($h - V$) graph has been used in order to avoid error arising due to the kinetic energy of water and turbulent motion.
- (v) The co-efficient of viscosity (η) of water is calculated by using eq. (6.3) with the observed value of the quantities involved.
- (vi) Proper precautions have been discussed and accuracy of measurement is checked.

Model questions and answers :**1. What do you mean by ‘streamline’ and ‘turbulent’ motion?**

Ans. If the pressure difference under which a liquid flows in a horizontal capillary tube is small, the liquid particles move in straight paths parallel to the axis of the tube. This type of motion is called ‘streamline’ motion.

On the otherhand, when pressure difference across the ends of the capillary tube is large, the liquid particles move in ‘zig-zag’ paths. This type of motion of liquid is called ‘**turbulent**’ motion.

2. What do you mean by ‘critical height’ and ‘critical velocity’?

Ans. Critical height (h_c) : When the value of h and hence pressure difference across the ends of a capillary tube exceeds certain value (h_c), then the motion of liquid flowing through the tube becomes turbulent. This height h_c is called critical height.

Critical velocity (V_c) : There is a particular velocity of flow of liquid below which the motion is streamline and above which the motion is turbulent. This particular velocity is called critical velocity. Critical velocity for a liquid depends on the density (ρ) of liquid, radius (r) of the capillary tube, the coefficient of viscosity (η) of the liquid. The expression for critical velocity is $v_c = \frac{K\eta}{\rho r}$. K is called Reynold’s number.

3. What is Reynold’s number (K)?

Ans. According to Reynold, the critical velocity (v_c) marking the transition from

the streamline to the turbulent motion of a liquid is given by

$$v_c = \frac{K\eta}{\rho r}$$

where K is a number called Reynold's number (for narrow tubes $K = 1000$). ρ is the density of the liquid and r is the radius of capillary tube through which liquid is flowing.

4. Can you perform this experiment with a tube of wider bore?

Ans. No, In that case, a small pressure difference across the tube will cause the liquid flowing through it turbulent.

5. How does the co-efficient of viscosity change with temperature?

Ans. In case of liquids, the co-efficient of viscosity decreases with the increase of temperature while in case of gases co-efficient of viscosity increases with the increase of temperature.

6. Why does the co-efficient of viscosity of water falls off with increasing temperature?

Ans. When the temperature of water increases, its molecules gain energy. As a result, the intermolecular separation increases and the cohesive force responsible for viscosity decreases. So the co-efficient of viscosity of water will decrease with the rise of temperature.

7. Why should the capillary remain horizontal?

Ans. The capillary tube through which the liquid flows must remain horizontal, otherwise the effect of gravity will come into play.

8. Is the velocity of water same everywhere inside the tube?

Ans. No, velocity of water is maximum along the axis of the tube and decrease towards the wall of tube from axis and minimum at the surface of contact with the tube.

9. Are there any assumptions in this method?

Ans. Yes. **First assumption :** There is no acceleration of water along the axis of the tube, which is not true.

Second assumption : The energy available due to pressure difference across the two ends of the capillary tube is spent entirely to overcome the viscous drag of the liquid flowing through the tube. This is also not true.

10. Is this method suitable for all types of liquids ?

Ans. No. This method is only suitable for liquids having low viscosity. For highly viscous liquids stoke's method may be employed.

11. Should the pressure difference across the ends of the capillary tube remain constant during a particular set?

Ans. Yes. If the pressure difference does not remain constant the rate of flow of water will change during a particular set.

12. Have you considered the effects of Kinetic energy of the liquid and its acceleration near the entrance end of the capillary tube?

Ans. No, their effects produces error in the determination of η . To eliminate these effects, the formula for η should be

$$\eta = \frac{\pi r^4}{8V(1+1.64r)} \rho g \left(h - \frac{kV^2}{g\pi^2 4^4} \right) \text{ where, } k \text{ is a constant whose value is nearly}$$

one.

Unit-7A □ Determination of the acceleration due to gravity (g) using a Bar Pendulum

Contents : The acceleration due to gravity (g) is measured with the help of a bar pendulum.

Introduction : A compound pendulum is a weighted rigid body of any shape capable of oscillating under gravity in a vertical plane about any horizontal axis passing through it. As a compound pendulum execute simple harmonic motion for small angular displacement, it helps us to find out the value of acceleration due to gravity (g). A bar pendulum (a long metallic bar) is actually a compound pendulum and is used to determine the value of g .

Bar Pendulum :

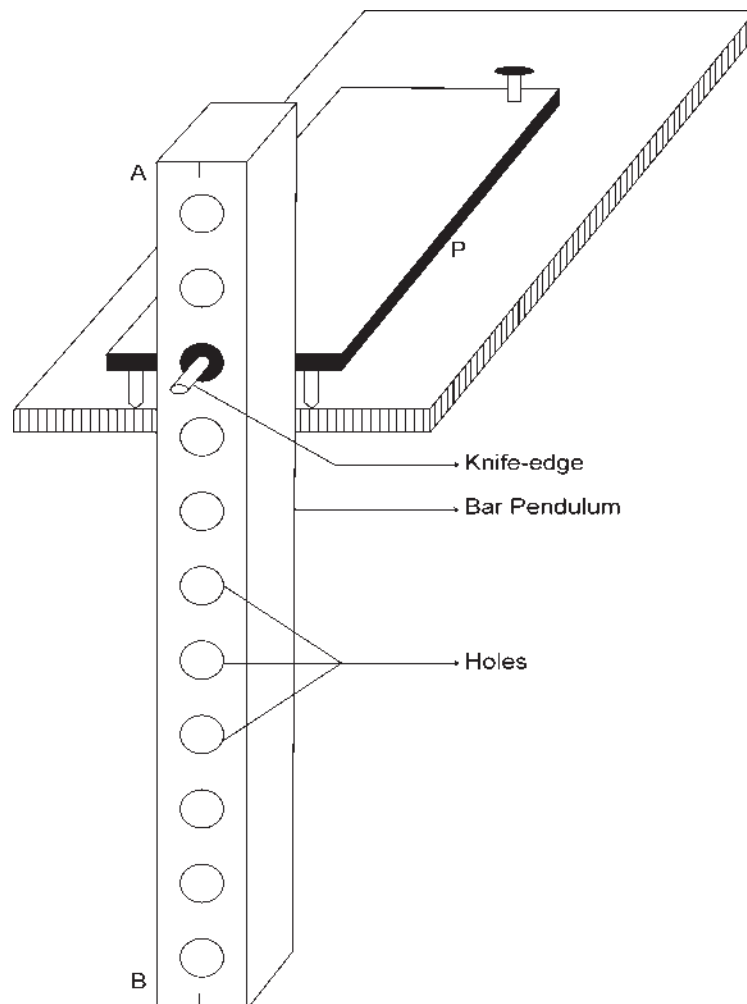

Fig. 7A.1 Bar Pendulum

Description :

- AB* → A bar pendulum. It consists of a metal bar (Fe or Brass) about 1 m long.
- H* → Series of circular holes on the bar of equal distances.
- K* → Knife-edge which passes through any one of the holes.
- P* → Platform with which knife-edge is fixed.
- L* → Levelling screw used to make platform horizontal.

The bar pendulum is suspended from a knife-edge and made to oscillate in a vertical plane.

Objective : To determine the acceleration due to gravity (g) by means of a Bar Pendulum.

Theory :

Definition : The acceleration acquired by a freely falling body under gravity is known as acceleration due to gravity (g).

SI unit of g is m/s^2

Working formula :

The acceleration due to gravity (g) is given by

$$g = 4\pi^2 \cdot \frac{L}{T^2} \dots (7A.1)$$

Where, T = Time period of oscillation of the bar pendulum.

L = Length of the simple equivalent pendulum. and $L = l_1 + l_2$,

l_1 and l_2 = Distances between the points of suspension from the centre of gravity (C.G) of pendulum, situated asymmetrically on either side of the C. G, about which the time periods are same.

Procedure :

1. The knife-edge is first made horizontal by means of levelling screws and tested with the help of a spirit-level placed on the platform. Two vertical lines are marked at the two ends (A and B) [Fig. 7A.1] of the bar pendulum.
2. The bar pendulum is placed horizontally on a sharp point and kept it in equilibrium position. The position of C. G of the bar is marked.
3. Now the bar is suspended on the knife-edge which is introduced in a hole nearest to one end (say, A) of the bar.
4. The lower vertical mark at the end B of bar is then focussed by a telescope avoiding parallax, keeping the bar at rest.
5. The pendulum is made to oscillate with very small amplitude (less than 4°) in a vertical plane.
6. Time for 30 complete oscillations is noted with the help of a precision stop-watch three times and mean time period (T) is determined.
7. The distance (d) of the hole i.e., axis of suspension from the fixed end A is measured by a metre scale.
8. The operations (3) to (7) are repeated for other holes situated on one side of C. G. The values of T and d are determined in each case.
9. Now, the bar is inverted and similar operations (3) to (7) are repeated for each hole (knife-edge) situated on the other side of C. G.

Time period (T) corresponding to each hole and the distance (d) of the holes, i.e., knife-edges from the same end A are determined.

10. A graph is then drawn with the distance of the holes (knife-edges) from the fixed end A along X -axis and the corresponding time period (T) along Y -axis. The nature of the graph is shown in Fig.7A.1.

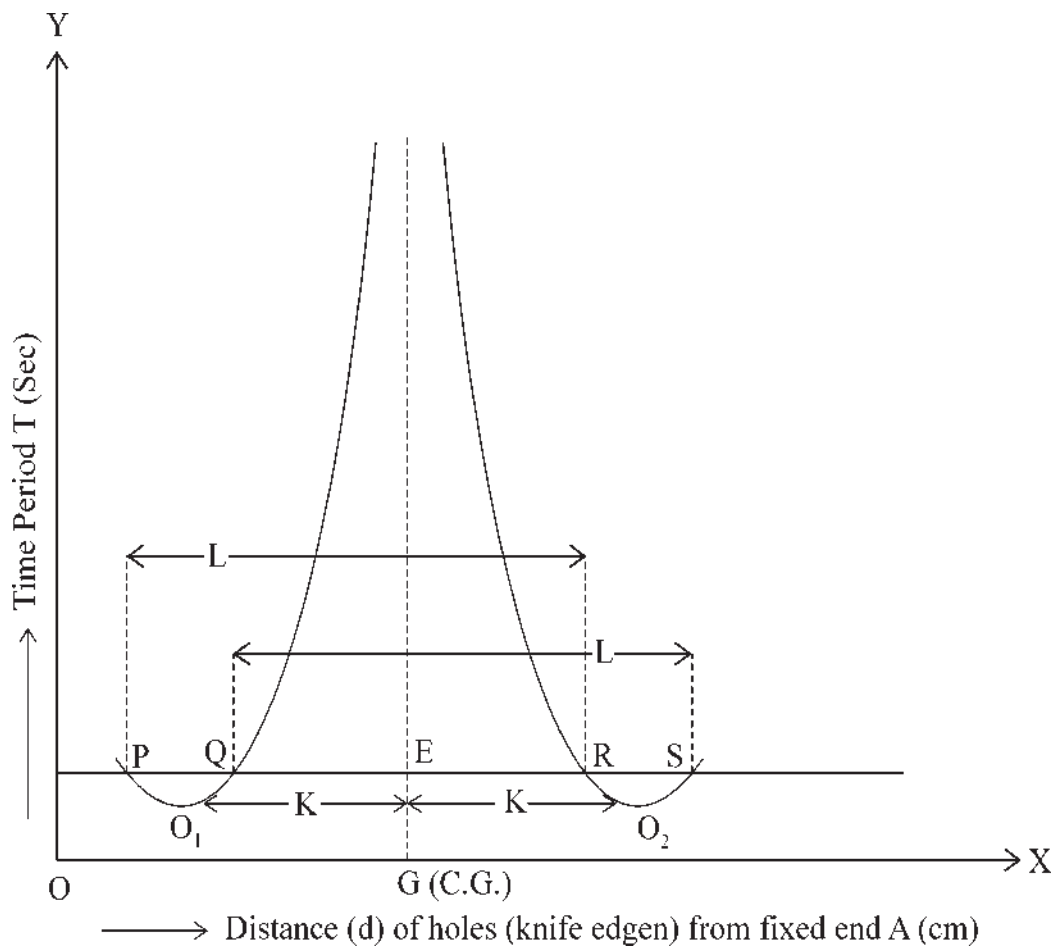

Fig. 7A.2

11. A horizontal line $PQRS$ is drawn which intersect the curves at P, Q, R, S . Measuring the distances PR and QS , the length of equivalent simple pendulum L is determined where $L = \frac{PR + QS}{2}$.

12. We can calculate 'g' by using value of L and T from graph in equation. (7A.1).

Experimental results :

(A) Determination of time period (T) and distance (d) of holes (knife-edges) from one fixed end A.

Table-1

Serial no of holes from one are fixed end A		Distance of the hole (knife-edge) from the fixed end A (cm)	Time for 30 oscillations (S)	Mean time (t) (S)	Time period (T) (S)
On one side of C. G	1.
	2.
	3.
	etc.
on other side of C. G	1.
	2.
	3.
	etc.

(B) Determination of L and T from d – T graph :**Table-2**

No. of obs.	Length PR from graph (7A.1) (cm)	Length QS from graph (7A.1) (cm)	Length of equivalent simple pendulum $L = \frac{PR + QS}{2}$ (cm)	Corresponding value of time period (T) (s) (from graph 7A.1)
1.
2.
3.

Calculations :

We can calculate 'g' using ($d - T$) graph (Fig. 7A.1) :

Drawing different horizontal lines, we can find different values of L and corresponding value of T (consult procedure-11)

Then substituting these values of L and T in equation (7A.1)

$g = 4\pi^2 \cdot \frac{L}{T^2}$, we get three values of 'g'. Their mean is then found out.

Result :

The acceleration due to gravity (at the place of experiment)

$$g = \dots\dots\dots \text{cm/s}^2 = m/s^2$$

Discussions :

1. The amplitude of oscillation must be very small (within 4° of arc) during the

measurement of time period.

2. The knife-edges must be kept horizontal and the pendulum must oscillate in a vertical plane. There should not be any rotational motion of the pendulum during oscillation.
3. The time period should be noted very accurately as far as possible by using a precision stopwatch and a telescope.
4. There should not be any air current in the vicinity of the pendulum.
5. We can also calculate 'g' by drawing lT^2 along X -axis and l along Y -axis, where l is the distance of the holes from C. G. of the bar and T is the corresponding time period. The graph is a straight line. The slope of this curve, $m = \frac{g}{4\pi^2}$.
6. The radius of gyration (k) of the pendulum about an axis passing through its C. G. can be calculated with the help of ($d - T$) graph.

Maximum proportional error :

From equation (7A.1), we have,

$$g = 4\pi^2 \cdot \frac{L}{T^2} = \frac{4\pi^2 \cdot \left(\frac{L_x}{2}\right)}{\left(\frac{t}{30}\right)^2}$$

where, $L = \frac{L_x}{2}$ and $T = \frac{t}{30}$

Therefore,
$$\frac{\delta g}{g} \Big|_{\max} = \frac{\delta L_x}{L_x} + 2 \cdot \frac{\delta t}{t}$$

$$\therefore \text{Maximum percentage error in } g = \frac{\delta g}{g} \Big|_{\max} \times 100\% = \dots\%$$

Knowing the smallest value of metre scale ($\delta x = 0.2 \text{ cm}$) and that of stop watch ($\delta \tau$), the maximum percentage error can be calculated.

Conclusion :

The measured value of the acceleration due to gravity (g) is accurate within the errors involved in the experimental arrangement.

Key Words : (i) Acceleration due to gravity ; (ii) Bar pendulum (ii) Radius of gyration (iv) Simple equivalent pendulum.

Summary :

- (i) Acceleration due to gravity (g) is defined and of the method of determination of g by a Bar pendulum is discussed.
- (ii) The amplitude of oscillation is kept very small and the pendulum is allowed to oscillate in a vertical plane avoiding any rotational motion.
- (iii) The period of oscillation (T) is measured accurately by a precision stop-watch and a telescope for different values of distance (d) of the knife-edge from a fixed end.
- (iv) The length (L) of equivalent simple pendulum and the corresponding time period (T) is determined by drawing $d - T$ graph.
- (v) The value of ' g ' is determined by substituting the values of L and T in equation

(7A.1).

(vi) The precautions to be taken for measurement of 'g' have been discussed. Evaluation of proportional error is mentioned.

(vii) Accuracy of the measurement is checked.

Model questions and answers :

1. What do you mean by 'centre of suspension' and 'centre of oscillation' of a compound pendulum?

Ans. Centre of Suspension : It is the point where horizontal axis of oscillation meets the vertical sections of the pendulum taken through its C. G.

Centre of oscillation : It is a point on the other side of C. G. of the pendulum at a different distance than that of the centre of suspension such that the period of oscillation is the same as that about the centre of suspension. Centre of oscillation and centre of suspension are interchangeable.

2. What is simple equivalent pendulum?

Ans. It is a simple pendulum whose length is such that its period is the same as that of a compound pendulum.

3. What would happen if the centre of suspension coincides with the C.G?

Ans. When centre of suspension of the bar pendulum coincides with its C. G, the time period of oscillation of the pendulum will be infinite.

4. When is the period of Compound pendulum minimum?

Ans. The time period of a compound pendulum is minimum when the distance

of the centre of suspension from its C. G is equal to the radius of gyration of the pendulum about an axis parallel to the axis of rotation and passing through the C. G.

5. How many points are there about which the time periods of a compound pendulum are the same?

Ans. There are four points, two on each side and collinear with the C. G. about which time periods are same.

6. Why is it necessary to make the knife-edges horizontal?

Ans. The knife-edges are made horizontal to avoid the slipping of the pendulum and to make it oscillate in a vertical plane.

7. What are the different sources of error in this experiment?

Ans. The different sources of error are (i) finite amplitude of oscillation (ii) the curvature of the knife edge. (iii) the buoyancy and viscosity of air (iv) yielding of the support (v) the flow of air alongwith the pendulum.

**Unit-7B □ Determination of the acceleration due to gravity (g)
using a Kater's pendulum**

Contents : The acceleration due to gravity (g) is measured with the help of a Kater's pendulum.

Introduction : Kater's pendulum which is also called 'reversible pendulum' is actually a compound pendulum— a rigid body of any shape capable of oscillating in a vertical plane under gravity about any axis passing through it. In the bar pendulum one knife-edge is used to oscillate it in a vertical plane whereas in Kater's pendulum two knife-edges are used. To determine ' g ' more precisely, Bessel used two adjustable masses positioned on the pendulum rod between two knife-edges to make periods of oscillation about two knife-edges very nearly equal. The measurement of ' g ' by Kater's pendulum with the help of Bessel's formula gives us very accurate result.

Kater's pendulum :

Description :

PQ → A Kater's pendulum. It is a metal (Brass) rod about 1m long.

K_1 and K_2 → Two movable knife-edges positioned on the rod, turned inwards to face each other.

A and B → Two equal cylinders placed beyond K_1 ,
 K
 A is made of box wood and ' B ' is made of brass.

C and D → Two equal cylinders, smaller in size placed between knife-edges K_1 and K_2 .
 C is made of box wood whereas D is made of brass.

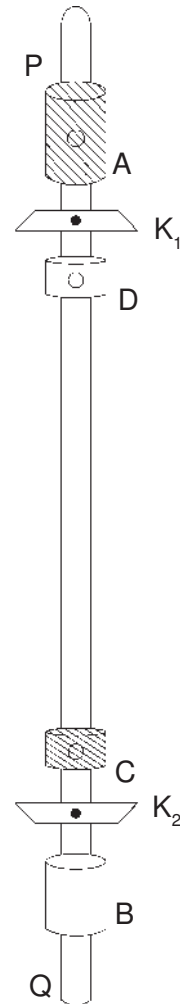

Fig. 7B.1

The pendulum is allowed to oscillate about any of the knife-edges in a vertical plane by placing the corresponding knife-edge on a metallic plate which is rigidly fixed on a permanent support.

Objective : To determine the acceleration due to gravity by means of a Kater's pendulum.

Theory :

Defintion : The acceleration produced in a freely falling body on account of the force of gravity is known as acceleraion due to gravity (g).

SI unit of g is m/s^2 .

Working formula : The acceleration due to gravity (g) can be found out by using Bessel's formula given by

$$\frac{8\pi^2}{g} = \frac{T_1^2 + T_2^2}{l_1 + l_2} + \frac{T_1^2 - T_2^2}{l_1 - l_2} \dots (7B.1)$$

Where, T_1 and T_2 = Time periods of the Kater's pendulum about its two knife-edges which are very nearly equal.

l_1 and l_2 = Distances of the two knife-edges from the centre of gravity (C. G) of the pendulum.

Procedure :

1. Keeping the cylinder B in the downward position, the pendulum is suspended from one of its knife-edges (say, K_1) [Fig. 7B.1]. A vertical sharp mark is drawn along the length of the pendulum and the mark is focussed through a telescope avoiding parallax keeping the pendulum at rest.
2. The pendulum is now allowed to oscillate freely about the knife-edge K_1 with very small amplitude in a vertical plane. The time for small number of oscillations (say, 5) is determined by means of a precision stop-watch reading upto 0.1s.
3. Now the pendulum is placed on the second knife-edge K_2 and again time for the same number of oscillation i.e.5 is measured. Usually these two times differ much.

4. Then the time for the same number of oscillations i.e, 5 about the knife-edges K_1 and K_2 are measured after shifting the smaller cylinder D slightly in one direction. If the difference between these two times is increased, the cylinder D should be shifted in the opposite direction. Otherwise, the cylinder should be shifted in the same direction in subsequent adjustments.
5. The shifting of cylinder D should be continued in the same direction as before and times for more number of oscillations (say, 10, 15, 20 etc) about K_1 and K_2 are noted until the two times are nearly equal.
6. When times for more than 20 oscillations are noted, the difference between the times, about K_1 and K_2 for a given number of oscillations should be decreased by adjusting the position of smaller cylinder C slightly. Finally, these two times (T_1, T_2) for 50 oscillations about K_1 and K_2 are made very nearly equal, their difference should be less than $2s$.
7. Now the time for 50 oscillations about each knife-edge is measured thrice and the mean time for 50 oscillations about each knife-edge is calculated. From this, time periods T_1 and T_2 about the knife-edges K_1 and K_2 are calculated.
8. To locate the centre of gravity (C. G) of the pendulum, the pendulum is removed from its support and balanced on a sharp wedge placed on the table. Then the balancing point is marked which is the position of C. G of the pendulum. The distances (l_1, l_2) of the knife edges K_1 and K_2 from the C.G are measured by a metre scale.
9. Substituting the values of T_1, T_2, l_1 and l_2 in equation (7B.1), we can calculate the value of g .

Experimental results :**(A) Determination of the times of oscillations at the preliminary observations**

Least count of the stop-watch = sec.

Table-1

No. of obs	Adjustments by shifting	No. of Oscillations observed	Total time for oscillation about the knife-edge	
			$k_1 [t_1]$ (sec.)	$k_2 [t_2]$ (sec)
1.	Cylinder <i>D</i> (heavy mass)	5		
2.		5		
3.		10		
4.		10		
5.		15		
		15		
1.	Cylinder <i>C</i> (lighter mass)	20		
2.		20		
3.		25		
4.		30		
5.		30		
etc.		etc.		

(B) Determination of final time periods T_1 and T_2 **Table-2**

No. of obs	Oscillations about the Knife-edge	Time for 50 oscillations (sec)	Mean time for 50 oscillations (sec)	Time period (sec) (T_1 and T_2)
1.	K_1	$T_1 = \dots\dots\dots$
2.				
3.				
1.	K_2	$T_2 = \dots\dots\dots$
2.				
3.				

(C) Determination of the distances of the Knife-edges (K_1, K_2) from the C. G of the pendulum**Table-3**

No. of obs	Distance of K_1 from C. G l_1 (cm)	Mean l_1 (cm)	Distance of K_2 from C. G. l_2 (cm)	Mean l_2 (cm)
1.
2.	...			
3.	...			

Calculations :

From equation (7B.1) we get,

$$\frac{8\pi^2}{g} = \frac{T_1^2 + T_2^2}{l_1 + l_2} + \frac{T_1^2 - T_2^2}{l_1 - l_2}$$

Substituting the values of T_1 , T_2 , l_1 and l_2 in the above expression, the value of g is obtained.

Result : The acceleration due to gravity $g = \dots\dots\dots$ m/s²

Discussion :

1. The amplitude of oscillation must be kept very small such that formula employed holds good.
2. The knife-edges must be adjusted horizontal and parallel to each other.
3. During preliminary observations, times of oscillations should be noted for smaller number of oscillations. Final observations for time periods should be noted for a large number of oscillations.
4. To increase accuracy, time periods should be measured by coincidence method.
5. Using the formula, $T = T_0 \left(1 - \frac{\theta_1 \theta_2}{16} \right)$ where T_0 and T are observed and corrected time period, θ_1 and θ_2 are the half angles of swing in radians at the start and end respectively, we can make correction for finite arc of swing.

Maximum proportional error :

We find from equation (7B.1)

$$\frac{8\pi^2}{g} = \frac{T_1^2 + T_2^2}{l_1 + l_2} + \frac{T_1^2 - T_2^2}{l_1 - l_2}$$

The second term on the right hand side of the above expression is small compared to the first term since $T_1^2 \approx T_2^2$. Thus second term does not require much exact evaluation.

Therefore, we may write

$$g = 8\pi^2 \cdot \frac{l_1 + l_2}{T_1^2 + T_2^2}$$

$$\therefore \frac{\delta g}{g} \Big|_{\max} = \frac{\delta(l_1 + l_2)}{l_1 + l_2} + \frac{\delta(T_1^2 + T_2^2)}{T_1^2 + T_2^2}$$

$$\text{or, } \frac{\delta g}{g} \Big|_{\max} = 2 \cdot \frac{\delta l}{l_1 + l_2} + \frac{2\delta T}{T_1} \text{ [since } T_1 \approx T_2 \text{]}$$

Here, $\delta l = 0.2$ cm (2 division of metre scale)

$\delta t =$ one smallest division of stop watch = sec

Using $l_1 + l_2$ and T_1 from the observed data, we can

calculate $\frac{\delta g}{g} \Big|_{\max}$

$$\therefore \text{Maximum percentage error in } g = \frac{\delta g}{g} \Big|_{\max} \times 100\% = \dots\dots\dots\%$$

Conclusion : Measured value of the acceleration due to gravity (g) is accurate within the errors involved in the experimental arrangement.

Key words : (i) Acceleration due to gravity ; (ii) Kater's pendulum ; (iii) Reversible pendulum.

Summary :

- (i) Acceleration due to gravity (g) is defined and the method of determination of g by a Kater's pendulum is discussed.
- (ii) The amplitude of oscillation is kept very small. The pendulum is allowed to oscillate freely in a vertical plane.
- (iii) Keeping the knife-edges horizontal and parallel to each other, the periods of oscillation T_1 and T_2 about two knife-edges K_1, K_2 are noted initially for small number of oscillations. The value of T_1 and T_2 are made nearly equal by adjusting the position of heavy cylinder D and increasing the number of oscillations upto 20 oscillations.
- (iv) When time for more than 20 oscillations are recorded, the difference between T_1 and T_2 is decreased by slightly adjusting the position of smaller cylinder C .
- (v) Finally, the difference between T_1 and T_2 for 50 oscillations are made very nearly equal by adjusting the position of smaller cylinder C . T_1 and T_2 are then calculated.
- (vi) The $C.G$ of the pendulum is determined and value of distance of K_1 and K_2 from $C.G$ (l_1 and l_2) are measured.
- (vii) Substituting the values of T_1, T_2, l_1 and l_2 in equation (7B.1), we get the value of g .
- (viii) The precautions to be taken for measurement of g have been discussed. Evaluation of Proportional error is mentioned.
- (ix) Accuracy of the measurement is checked.

Model questions and answers :

1. What are 'centre of suspension' and 'centre of oscillation'?

Ans. Consult answer of Q. No. 1 of model question, unit-7A.

2. What is simple equivalent pendulum?

Ans. See Answer of Q. No. 2 of model Q. unit 7A.

3. When the period of oscillation of a compound pendulum minimum?

Ans. See answer of Q. No. 4 of model question, unit 7A.

4. What would happen if the centre of suspension coincides with the C. G.?

Ans. Consult answer of Q. No. 3 of model Q. Unit 7A.

5. Why should the knife-edges be horizontal?

Ans. Otherwise, the bar may slip off and the pendulum would not oscillate in the vertical plane.

6. What are the uses of two adjustable cylinders in a Kater's pendulum?

Ans. The heavier cylinder is used to make rough adjustment whereas the lighter cylinders are used to make fine adjustment.

7. What are the main sources of error in this experiment?

Ans. Consult answer of Q. No. 7 of model Q. unit 7A.

8. How does this experiment give us correct result?

Ans. The working formula of this experiment contains two terms (i) first term contains $l_1 + l_2$ in the denominator. The distance between two knife-edges $l_1 + l_2$ can be measured accurately (ii) the denominator of the second term $l_1 - l_2$ involves certain inaccuracy since position of C. G can not be measured very accurately. But $T_1^2 - T_2^2$ is very small since $T_1 \approx T_2$, So error in $l_1 - l_2$ of second term effectively does not affect the result. Thus we can obtain most accurate result by this experiment.

Unit-8 □ Determination of thermal conductivity of a bad conductor by Lees' and Chorlton's method

Contents : Value of thermal conductivity of a bad conductor in the form of a disc is measured using Lees' and Chorlton's method.

Introduction : Thermal conductivity (k) is an important thermal property of a material which refers to its intrinsic ability to conduct heat. Depending on the value thermal conductivity, different substances are used for different purposes—as a conductor or insulator. So the determination of thermal conductivity of a material is very important. There are different methods for the determination of thermal conductivity of different substances such as, Searle's method is used to measure thermal conductivity of a good conductor (metal), thermal conductivity of glass (bad conductor) is measured in the laboratory taken in the form of tube. The determination of thermal conductivity of a bad conductor taken in the form of a thin disc by Lees' and Chorlton's method with Bedford's correction in the laboratory provides us most accurate result.

Apparatus :

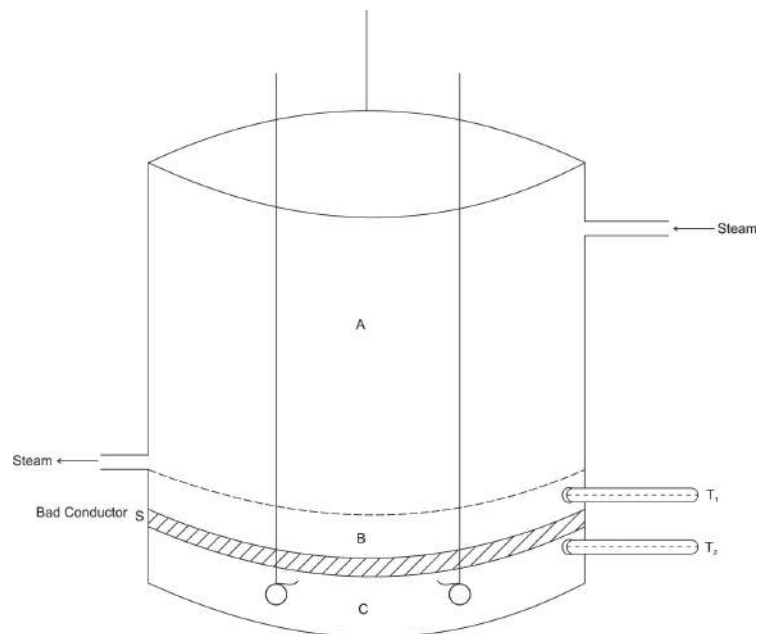

Fig. 8.1

Description :

- C* → Circular brass disc suspended by means of three strings from a ring on a retort stand.
- S* → Circular bad conducting sheet of uniform thickness which is placed on *C*.
- A* → A steam chamber placed on the sheet *S*.
- B* → Bottom of the steam chamber, a thick circular metal plate (disc).
- T_1 and T_2 → Two thermometers used to record the temperatures of *B* and *C*.
 T_1 should read upto 0.2°C while T_2 should read upto 0.1°C .

Diameters of *B*, *C* and *S* are all the same.

Objective : To determine the thermal conductivity of a bad conductor using Lees' and Chorlton's method with Bedford's correction.

Theory :

Definition : Thermal conductivity of a material is defined as the rate at which heat is transferred by conduction normally per unit cross-sectional area of a slab made of that material from one face to other in the steady state when the temperature gradient is unity.

S. I. unit of thermal conductivity is $\text{Js}^{-1}\text{m}^{-1}\text{K}^{-1} = \text{Wm}^{-1}\text{K}^{-1}$

Working formula :

Thermal conductivity of the material of a bad conducting sheet is given by

$$K = \frac{Qd}{A(\theta_1 - \theta_2)} \dots (8.1)$$

where, A = cross-sectional area of the bad conducting sheet.

d = thickness of the sheet.

θ_1, θ_2 = temperatures of the two opposite faces of the sheet in the steady state and $\theta_1 > \theta_2$.

Q = Quantity of heat conducted per second normally through the sheet in the steady state.

Q is given by

$$Q = ms \left(\frac{d\theta}{dt} \right)_{\theta_2} \dots (8.2)$$

where, m = mass of the lower metal disc (C) of the apparatus [Fig. 6.1, chap-1 unit-6]

s = Specific heat of the material of the lower disc.

$\left(\frac{d\theta}{dt} \right)_{\theta_2}$ = rate of cooling of the lower disc at its steady temperature θ_2 under experimental condition.

Bedford's correction factor

$$f = \frac{r+2h}{2r+2h} \dots (8.3)$$

where, r = radius of the lower circular metal disc (C)

h = thickness of the lower disc.

Therefore, considering Bedford's correction, thermal conductivity of the material of the sheet is

$$K = \frac{msd \left(\frac{dQ}{dt} \right)_{\theta_2}}{A(\theta_1 - \theta_2)} \times \frac{r+2h}{2r+2h} \dots (8.4)$$

where, $\left(\frac{d\theta}{dt}\right)_{\theta_2}$ = rate of cooling of the lower disc at its steady temperature θ_2 without the experimental sheet (S) on it.

Procedure :

1. The mass (m) of the lower disc C (Fig. 8.1).
2. (a) To find the area (A) of the disc C (or sheet S), [Fig. 8.1, chap-1] a thread is wound round C, n times (say 5 or 6) avoiding overlapping. Total length (L^1) of the thread required is measured by a metre scale and number of turns (n) is noted. Then the circumference of the disc is $L = \frac{L^1}{n}$ and radius of the disc C is $r = \frac{L}{2\pi}$. Therefore, the cross-sectional area (A) of the disc C is $A = \pi r^2 = \frac{L^2}{4\pi}$.

(b) The specific heat (s) of the material of the disc C is found out from the table of constants.
3. After determining the vernier constant of a slide-callipers, the thickness (h) of the lower disc C is measured at its different places and mean value of h is determined.
4. The thickness (d) of the bad conducting sheet (S) is measured by a travelling microscope. At first the vernier constant of the vertical scale of microscope is determined. Then a piece of paper with some cross marks (1,2,3 etc) on it at different places is attached to the upper disc B. Now a cross mark (say 1) is focussed by the microscope keeping the experimental sheet S between the discs B and C. The reading (R_1) of the microscope is noted. Then reading

(R_2) of the same cross mark (1) is taken without the sheet S between B and C . Hence, the thickness of the sheet is, $d = R_1 \sim R_2$. Following the same process the value of d are measured focussing other cross-marks. The mean value of thickness (d) is calculated.

5. After noting initial errors of the thermometers T_1 and T_2 , if any, steam is passed into the chamber A . Then temperatures of B and C are recorded using T_1 and T_2 at intervals of 5 minutes until the thermometers show steady temperature for atleast 10 to 15 minutes.

The correct value of steady temperatures θ_1 and θ_2 of discs B and C are recorded incorporating the initial errors of the thermometers.

6. Now the steam chamber A and the experimental sheet S are removed. The lower disc C is then heated slowly by a burner until its temperature is raised about 10°C higher than its steady temperature θ_2 . Then burner is removed and the disc C is allowed to cool down. Recording of temperature of disc C by a stop-watch is started when its temperature is 5° or 6°C above its steady temperature θ_2 . The temperature is noted at an interval of 15 sec or 30 sec. until its temperature falls below its steady temperature θ_2 by about 5° or 6°C .

7. To find $\left(\frac{d\theta}{dt}\right)_{\theta_2}$, we may draw a graph plotting time (t) along X-axis and the corresponding temperature (θ) along Y-axis during cooling. This curve is called **cooling curve** (Fig.1). A tangent is drawn at the point on the curve corresponding to steady temperature θ_2 of disc C . Measuring the slope of the tangent the value of $\left(\frac{d\theta}{dt}\right)_{\theta_2}$ can be found out.

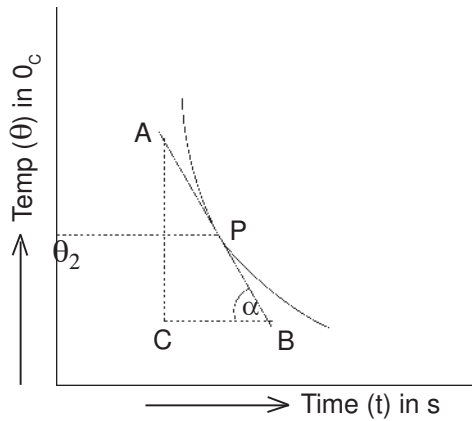

Fig.1

Let P be a point of the curve corresponding to temperature θ_2 . Then the slope of the tangent AB drawn at P

$$= \tan \alpha = \frac{AC}{BC} = \left(\frac{d\theta}{dt} \right)_{\theta_2}$$

8. Thus knowing the values of m , s , A , d , $(\theta_1 - \theta_2)$, r , h and $\left(\frac{d\theta}{dt} \right)_{\theta_2}$, the value of thermal conductivity K of the material of bad conducting sheet can be calculated using the equation (8.4).

Experimental results :

(A) Mass (m) and specific heat (s) of the material of lower disc C

Mass of the lower disc C = $m = \dots\dots\dots$ kg (supplied)

Specific heat of the material of the disc C

$$= s = \dots\dots\dots \text{ J kg}^{-1} \text{ K}^{-1} \text{ (supplied)}$$

(B) Determination of radius (r) and area (A) of the sheet S or disc C.**Table-1**

No. of obs.	Length of thread for n turns (L') cm	Mean (L') cm	Circumference of S or C $\left(L = \frac{L'}{100n}\right)m$	Radius of sheet S or disc C $\left(r = \frac{L}{2\pi}\right)m$	Area of sheet S ($A = \pi r^2$) m^2
1.					
2.					
3.					
4.					
5.					

(C) Determination of thickness (h) of the lower disc C by slide callipers.

Vernier constant of slide callipers = cm

Instrumental error of slide callipers (e) = + cm

Table-2

No. of obs.	Reading of			Mean (h') cm	correct ($h = h' - e$) cm	correct thickness (h) m.
	Main scale (S) cm	Vernier ($V = v.r \times v.c$) cm	Total ($h' = S+V$) cm			
1.			
2.			
3.
4.			
5.			

(D) Determination of the thickness (d) of the sheet S by a travelling microscope.

vernier constant of the vertical scale of travelling microscope (v. c) = cm

Table-3

No. of obs.	Reading of cross-mark on B with sheet S between B and C			Reading of the same cross-mark on B without the sheet S between B and C.			Thickness of the sheets (d) = $(R_1 \sim R_2)$ cm	Mean value of (d) cm	Mean (d) m
	Main scale reading (S) cm	Vernier reading $(V = v. r \times v. c)$ cm	Total $R_1 = (S + V)$ cm	Main scale reading (S) cm		Total $R_2 = (S + v)$ cm			
1.									
2.									
3.									
4.									
5.									

(E) Time-temperature records of B and C for steady state :

Room temperature = °C

Initial Corrections, if any, between the thermometers =°C

Table-4

Time in minutes →	0	5	10	15	20	25	30	35	40
Temperature of disc B (°C)→	= θ_1	= θ_1	= θ_1
Temperature of disc C (°C)→	= θ_2	= θ_2	= θ_2

(F) Time-temperature records of the disc C during its cooling.

Room temperature =°C

Table-5

Time in sec (t) →	0	15	30	45	50	65
Temperature (θ) of disc C (°C)→

Calculations :

From equation (8.4), we get,

$$K = \frac{mRd \left(\frac{d\theta}{dt} \right)_{\theta_2}}{A(\theta_1 - \theta_2)} \times \frac{r + 2h}{2r + 2h}$$

The value of $\left(\frac{d\theta}{dt} \right)_{\theta_2}$ is obtained from the cooling curve (Procedure-7). Substituting

the known values of $m, s, d, A, r, h, (\theta_1 - \theta_2)$ and $\left(\frac{d\theta}{dt} \right)_{\theta_2}$ in the above expression, the value of thermal conductivity (K) is obtained.

Result : Thermal conductivity of the material of the bad conducting sheet
 $K = \dots \text{ Wm}^{-1} \text{ K}^{-1}$

Discussions :

1. The diameter of the sheet S should be large in comparison with its thickness to minimise loss of heat due to radiation.
2. Steady temperatures θ_1 and θ_2 of disc B and C should be recorded for atleast

15 minutes when they remain steady.

3. During cooling, the temperature of the lower disc C should be recorded at an interval of 15 second or $\frac{1}{2}$ minute if cooling rate is very slow.
4. The diameter of the sheet S should be made equal to those of discs B and C .
5. The apparatus should be screen off from direct heating from boiler by a wooden partition.
6. The rate of cooling of disc C is recorded without the experimental sheet on it. Bedford's correction must be used to get the rate of cooling under experimental condition.
7. We can also find rate of cooling $\left(\frac{d\theta}{dt}\right)$ of disc C at its steady temperature

θ_2 i.e., $\left(\frac{d\theta}{dt}\right)_{\theta_2}$ by drawing a graph with average temperature (θ) of the disc C along X -axis and the corresponding rate of cooling along Y -axis. The graph would be a straight line.

Maximum proportional error :

From equation (8.4), we get,

$$K = \frac{msd \left(\frac{d\theta}{dt}\right)_{\theta_2}}{A(\theta_1 - \theta_2)} \times \frac{r+2h}{2r+2h}$$

The above expression may be written as

$$K = \frac{msd \left(\frac{\theta' - \theta''}{t}\right)}{\left(\frac{L^2}{4\pi}\right)(\theta_1 - \theta_2)} \times \frac{r+2h}{2r+2h}$$

where, $\frac{d\theta}{dt} = \left(\frac{\theta' - \theta''}{t}\right)$, $A = \pi r^2 = \frac{L^2}{4\pi}$

Hence, maximum proportional error in K is

$$\frac{\delta K}{K} |_{\max} = \frac{\delta m}{m} + \frac{\delta d}{d} + \frac{\delta(\theta' - \theta'')}{\theta' - \theta''} + \frac{\delta t}{t} + 2 \frac{\delta L}{L} + \frac{\delta(\theta_1 - \theta_2)}{\theta_1 - \theta_2} + \frac{\delta r + 2\delta h}{r + 2h} + \frac{2\delta r + 2\delta h}{2r + 2h}$$

(∵ s is known)

As m is large, its contribution is negligible. Other errors are :

$\delta d = 2 \times v. c$ of travelling microscope.

$\delta(\theta' - \theta'') = \delta(\theta_1 - \theta_2) = 2 \times 1$ division of thermometer

$\delta t \approx 2$ sec

$\delta h = v. c$ of slide callipers

$\delta L = 2$ division of metre scale = 0.2 cm.

Substituting the above errors and experimentally observed values of different quantities, we can calculate $\frac{\delta K}{K} |_{\max}$

Therefore, maximum percentage error = $\frac{\delta K}{K} |_{\max} \times 100\% = \dots \%$

Conclusion : Measured value of the thermal conductivity of a bad conductor is accurate within the errors involved in the experimental arrangement.

Key words : (i) Thermal conductivity (ii) steady state (iii) Bedford's correction.

Summary :

- (1) The measurement of thermal conductivity (K) of a bad conductor in the form of a disc using Lees' and Chorlton's method with Bedford's correction is discussed.
- (ii) In the steady or static part of the experiment the steady temperature θ_1 and θ_2 of the discs B and C are measured very accurately by the thermometers T_1 and T_2 .

- (iii) In the cooling i.e, **dynamic part** of the experiment, the temperatures (θ) of the lower disc C and the corresponding time (t) during cooling are measured very accurately with the help of a precision stop watch and a sensitive thermometer T_{2A} without the sheet S on it.
- (iv) Drawing the $(\theta - t)$ curve, called **cooling curve**, the value of $\left(\frac{d\theta}{dt}\right)_{\theta_2}$ is calculated by drawing a tangent at the point on the curve corresponding to θ_2 . $\left(\frac{d\theta}{dt}\right)_{\theta_2}$ = slope of tangent drawn.
- (v) As greatest source of error lies in the measurement of rate of cooling $\left(\frac{d\theta}{dt}\right)_{\theta_2}$, it must be calculated accurately.
- (vi) In the present method, the rate of cooling of disc C is determined without the experimental sheet on it. So to obtain correct value of $\left(\frac{d\theta}{dt}\right)_{\theta_2}$ under experimental condition, Bedford's correction term has been incorporated.
- (vii) Thermal conductivity (K) is calculated by using equation (8.4) with the observed value of the quantities involved.
- (viii) Precautions to be taken are discussed.
- (ix) Accuracy of measurement is checked.

Model questions and answers :

1. What is thermometric conductivity?

Ans. Thermometric conductivity or diffusivity of a substance is the ratio of thermal conductivity (K) and thermal capacity per unit volume.

\therefore Thermometric conductivity (h) = $\frac{K}{ps}$. Where, p and a are the density and specific heat of the substance.

2. Does the value of K depend on the dimension of the substance?

Ans. No, the value of K depends only on the material of the substance.

3. Can this method be used to measure thermal conductivity of a good conducting disc?

Ans. No. In case of a good conducting disc, the temperatures θ_1 and θ_2 will be nearly equal and measurement of their difference will be very difficult.

4. Can you apply this method to measure thermal conductivity of a liquid?

Ans. Yes, In this case the experimental liquid is to be taken in a thin walled copper receptacle with edges made of bad conductors and then set it in place of the slab.

5. Why is the specimen taken in the form of a disc?

Ans. When the specimen has small thickness and large area of cross-section, the amount of heat conducted increases. In this case, the radiation loss through the curved surface of the specimen is very small. This idea is considered to develop the theory of this experiment.

6. What are the factors on which the rate of cooling depend?

Ans. The rate of cooling depends on the surface area, nature of surface and also on the temperature difference between the body and the surroundings. Rate of cooling increases with the increase of surface area and temperature difference.

7. Why do you measure the thickness of the slab (S) in situ?

Ans. When the slab is placed between the two discs, its effective thickness decreases slightly and becomes less than its actual thickness. Therefore, the thickness (d) of the slab is to be measured under the experimental condition of heat flow.

8. What is the greatest source of error in this measurement?

Ans. In this experiment, greatest source of error comes from the measurement of

$\left(\frac{d\theta}{dt}\right)_{\theta_2}$, rate of cooling at the steady temperature θ_2 .

9. (a) What is Bedford's correction ? (b) If the correction is not made, what kind of error-random or systematic is introduced? (c) Can you perform the experiment without introducing Bedford's correction?

Ans. (a) In actual experiment, the rate of cooling of the lower disc C at its steady

temperature *i.e.* $\left(\frac{d\theta}{dt}\right)_{\theta_2}$ is measured with the experimental slab placed on it.

In this case heat is radiated from the bottom and side surfaces of the disc C. However, in the present method the rate of cooling of disc C is measured without the slab on it. Heat is radiated here from top, bottom and side surfaces

of the disc making $\left(\frac{d\theta}{dt}\right)_{\theta_2}$ higher. So, Bedford introduced a multiplying factor

to correlate these two experiments which is known as **Bedford's correction**. This correction factor is the ratio of the two radiating surface areas.

(b) This error is called systematic error.

(c) Yes, Bedford's correction will not be required if the rate of cooling of lower disc C is measured with the slab S on it. But the rate of cooling will be smaller

in this case, hence the error in the measurement of $\frac{d\theta}{dt}$ will be greater.

10. What is Newton's law of cooling?

Ans. This law states that rate of radiation from a hot body is directly proportional to the temperature difference between the body and the surroundings provided this difference of temperature is small.

11. The experimental arrangement should be placed in a room where there is no irregular air current. Why?

Ans. This experiment takes reasonable time to record the data of steady state and for drawing cooling curve. During this time the surrounding condition (air current and temperature) should remain same, otherwise there will be change in the rate of loss of heat due to radiation and convection.

Unit-9 □ To determine the surface tension of a liquid by Jaeger's method

Contents : The surface tension of a liquid (water) is measured by Jaeger's method.

Introduction : Surface tension is a fundamental property of every liquid due to which the free surface of a liquid always try to contract spontaneously and occupy minimum surface area due to inter molecular attraction.

There are several methods for the determination of surface tension of different liquids e.g., capillary rise method. Jaeger's method, Sessible drop method, drop-weight method, jet method. The expression of excess pressure inside a spherical air bubble formed inside a liquid is used to determine the surface tension of the liquid by Jaeger's method. This method is particularly suitable for determining the temperature variation of surface tension of a liquid but not for the determination of its absolute value.

Apparatus :

Fig. 9.1

Descriptions :

- C* → A thin-walled glass tube with a fine capillary end O having diameter about 0.2 mm to 0.5 mm.
- B* → A beaker containing experimental liquid (water) in which the capillary end O of tube *C* is vertically immersed.
- T* → A glass tube connected to *C* by rubber tube.
- M* → Manometer connected to glass tube *T* with the help of another rubber tube. Kerosine (generally) is taken as monometric liquid.
- W* → Woulf's bottle where regulated supply of water from reservoir *R* is collected.
- P*₁, *P*₂ → Two screw caps, *P*₁ regulates supply of water from reservoir *R* to bottle *W*. *P*₂ regulates the pressure of air in the tube *C*.
- V* → A vessel containing heating liquid in which beaker *B* is immersed.
- Th* → A thermometer to record the temperature of experimental liquid.
- S'* → A stirrer.

Objective ; We are concerned here to determine the surface tension of a liquid (water) with temperature by Jaeger's method.

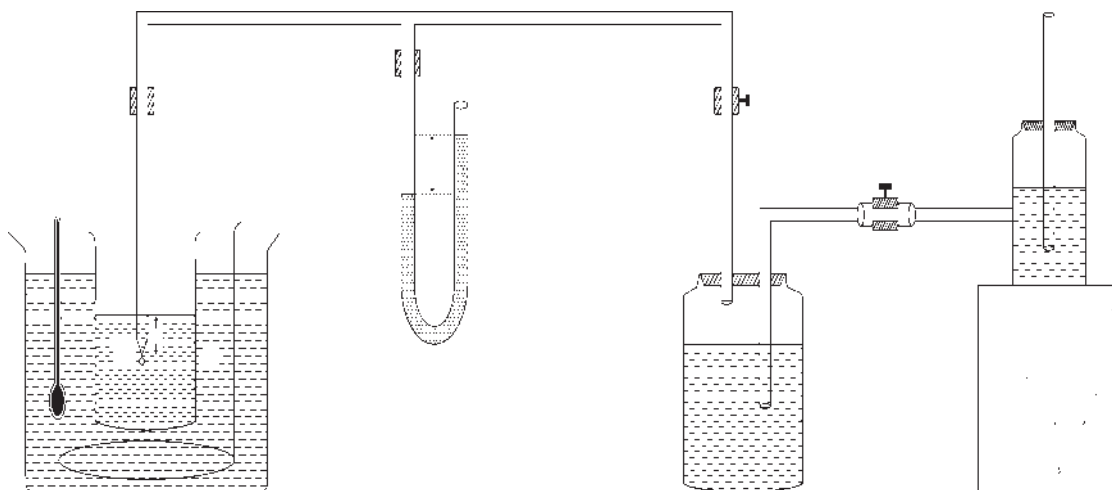
Theory :

Defintion : The surface tension of a liquid is defined as the force acting per unit length on an imaginary line drawn on the liquid surface at rest.

S. I. unit of surface tension is N/m.

Working formula :

The surface tension of a liquid (water) at a given temperature θ is given by

$$T = \frac{1}{2} f(r)g(h\rho - d\sigma) \quad \dots (9.1)$$

where, r = radius of the spherical air bubble formed inside the experimental liquid (water)

σ = density of the liquid (water) at temperature θ

h = maximum difference in heights of the manometric liquid at the moment the bubble breaks away.

ρ = density of the manometric liquid at temperature θ

g = acceleration due to gravity.

$f(r)$ = an unknown quantity and a definite function of the radius (r) having the same dimension as that of r .

$$\text{and } f(r) = \frac{2T_1}{g(h_1\rho - d\sigma_1)} \dots (9.2)$$

where, T_1 = Surface tension of the experimental liquid (water) at room temperature θ_1

σ_1 = density of the given liquid (water) at room temperature.

h_1 = maximum difference in heights of the manometric liquid when bubble breaks away.

Procedure :

1. At first, the densities of the experimental liquid (water) and of the manometric liquid (kerosine) are measured with the help of a specific gravity bottle if not supplied.
2. Making two scratch marks (say M_1 and M_2) on the tube C (Fig. 9.1, chap-1, unit-7), their distances (say d_1 and d_2) from the orifice O of tube C are measured by means of a travelling microscope by successively focussing the orifice and scratch marks.
3. Now the experimental liquid (water) is taken in the beaker B in which the tube C is immersed vertically. Then liquid level is adjusted such that first scratch mark M_1 just coincides with the liquid level. So the depth of the orifice O below liquid level is d_1 .
4. The temperature of the heating liquid (starting from room temperature) kept in the vessel V is noted by thermometer Th after stirring by stirrer S' . This

temperature is actually the temperature of experimental liquid (water) in *B*.

5. Adjusting the rate of flow of liquid (water) by screw cap P_1 and regulating flow of air through the tube *T* by screw cap P_2 [Fig. 7.1, chap-1, unit-7], air bubbles are formed at the orifice *O* at the rate of approximately one per 10 second.
6. Determining the vernier constant of the vertical scale of the travelling microscope, the liquid level in the open arm of manometer is focussed sharply. The readings of the microscope corresponding to the highest liquid levels (at which bubble breaks away) for a number of bubbles are noted. The highest of the readings (R_1) is to be accepted. Similarly, the lowest reading (R_2) of the microscope corresponding to the lowest liquid level in the closed arm of manometer is recorded. Thus the maximum difference of the liquid levels in the two arms of manometer at which bubble breaks is $h_1 = (R_1 - R_2)$.
7. Then the value of $f(r)$ is calculated by using known value of surface tension T_1 of the experiment liquid (water) at room temperature, its density σ_1 and the experimental values of h_1 , d and p is equation (9.2)
8. Again adjusting the liquid (water) level in the beaker, the depth of orifice below liquid level is made d_2 . The operations (5) to (7) are repeated and $f(r)$ is calculated. The mean value of $f(r)$ is then calculated.
9. To find out the value of surface tension of a liquid (water) at higher temperature, the vessel *V* is slowly heated to increase the temperature of the given liquid (water) in the beaker *B*. The temperature of liquid (water) is increased in steps of 5°C or 10°C and at each temperature the operations (3) to (6) are repeated for two depths d_1 and d_2 . Substituting the known values of $f(r)$, h , d , σ , p and g in equation (9.1), we get the values of surface tension of the experimental liquid at different temperatures.

10. Thereafter, a graph is drawn with temperature ($\theta^\circ\text{C}$) along X-axis and the corresponding surface tension (T) along Y-axis. The graph is a straight line for water between $30^\circ\text{C} - 80^\circ\text{C}$ (Fig.1). From this graph, we can find out surface tension of the liquid at any arbitrary temperature.

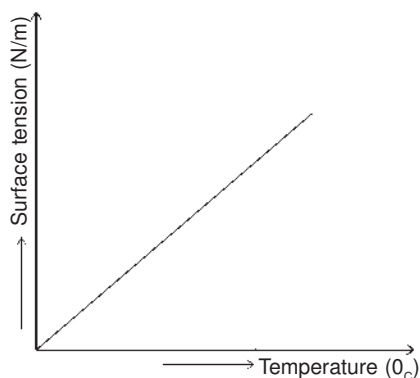

Fig. 1

Experimental results :

- (A) **Determination of the density (σ) of the experimental liquid (water) and density (ρ) of the manometric liquid (kerosine) by specific gravity bottle.**

Room temperature (θ_1) = $^\circ\text{C}$

density of water at room temperature (σ_1) = Kg/m^3 (supplied)
(..... $^\circ\text{C}$)

Table-1

liquid	Mass of the empty bottle (w_1) gm	mass of bottle + liquid (w_2) gm	mass of bottle + water at room temperature (w_3) gm	Density of liquid $= \frac{w_2 - w_1}{w_3 - w_1} \times \sigma_1 \text{ kg/m}^3$
Experimental	$\sigma = \dots\dots\dots \text{kg/m}^3$
Manometric	$\rho = \dots\dots\dots \text{kg/m}^3$

* omit the table if ρ and σ are supplied.

(B) Measurement of the depth of the orifice below the liquid

vernier constant (v.c) of the vertical scale of travelling microscope = cm

Table-2

Microscope focussed on	Microscope reading				Depth (cm)	Depth (m)
	Main scale (S) cm	vernier scale (V) = v. r × v c (cm)	Total = (S + V) (cm)	Mean (cm)		
Lower scratch mark M_1	$R_1 = \dots$	$d_1 = (R_1 - R_0)$ =	$d_1 = \dots$
Upper scratch mark M_2	$R_2 = \dots$	$d_2 = (R_2 - R_0)$ =	$d_2 = \dots$
Orifice 0	$R_0 = \dots$		

[N. B. Students may perform experiment for one depth (d) only, if not instructed for two depths]

(C) Determination of $f(r)$ Room temperature (θ_1) =°CDensity of experimental liquid (water) at room temperature (σ_1) = kg/m³ (supplied)Density of the manometric liquid (ρ) = kg/m³ (from table-1)

(E) Temperature—Surface tension records

$$g = 9.8 \text{ m/s}^2, \rho = \dots\dots \text{ kg/m}^3 \text{ (from table-1)}$$

$$f(r) = \dots\dots m \text{ (from table-3)}$$

Table-5

No. of obs.	Temperature of liquid (θ) ($^{\circ}\text{C}$)	Density of experimental liquid (σ) (kg/m^3) [from table-1]	Depth of orifice (m)	Corresponding h (m) (from table-4)	Surface tension $T = \frac{1}{2} f(r) \times g(h\rho - d\sigma)$ (N/m)	Mean T (N/m)
1.	Room temperature (θ_1) + 5°C = $\theta_2 = \dots^{\circ}\text{C}$		$d_1 = \dots\dots$	$h_1 = \dots\dots$	$T_1 = \dots\dots$	$T = \dots$
			$d_2 = \dots\dots$	$h_2 = \dots\dots$	$T_2 = \dots\dots$	
2.	Room temperature (θ_1) + 10°C = ($\theta_3 = \dots^{\circ}\text{C}$)		$d_1 = \dots\dots$	$h_1 = \dots\dots$	$T_1 = \dots\dots$	$T = \dots$
			$d_2 = \dots\dots$	$h_2 = \dots\dots$	$T_2 = \dots\dots$	
3.						
4.						
5.						

Calculations :

From equation (9.1), we get,

$$T = \frac{1}{2} f(r)g(h\rho - d\sigma)$$

Substituting the known values of $f(r)$, h , ρ , d , σ , g in the above expression, we can calculate value of T at a particular temperature (shown in table-5), but it is not the absolute value.

But to show the variation of surface tension of the liquid with its temperature, $\theta - T$ curve is to be plotted (consult procedure-10). The curve shows that surface tension of a liquid decreases with the rise of temperature. Using this graph we can also find out surface tension of the liquid at any arbitrary temperature provided the temperature lies within the range of observed value.

Result : The experimental value of the surface tension of the experimental liquid (water) at°C = N/m.

Discussions :

1. The apparatus should be perfectly air tight.
2. The narrow experimental tube should be free from any contamination like grease etc.
3. The manometric liquid should be of low density and non-volatile in nature. This makes the difference of liquid levels in the two limbs of manometer large.
4. Temperature of the liquid bath should be kept steady for a considerable time during the record of liquid level of manometer for each set.
5. Rate of bubbling should be made steady and slow for convenience of observation.

Maximum Proportional error :

From equation (9.1), we get,

$$\text{Surface tension } T = \frac{1}{2} f(r) g (h\rho - d\sigma) \dots (9.1)$$

During measurement of $f(r)$, value of T at a particular temperature is supplied

$$\text{So, we may write } \frac{\delta f(r)}{f(r)} \Big|_{\max} = \frac{\delta(h\rho - d\sigma)}{h\rho - d\sigma} \dots (9.3)$$

Assuming small variation of T and other quantities

$$\frac{\delta T}{T} \Big|_{\max} = \frac{\delta f(r)}{f(r)} + \frac{\delta(h\rho - d\sigma)}{h\rho - d\sigma}$$

$$\text{or, } \frac{\delta T}{T} \Big|_{\max} = \frac{2\delta f(r)}{f(r)}$$

$$\text{or, } \frac{\delta T}{T} |_{\max} = 2 \times \frac{h\delta\rho + \rho\delta h + \sigma\delta d}{h\rho - d\sigma} \text{ [using (9.3)]}$$

As contribution of term $h\delta\rho$ is very small ($\therefore \rho$ is supplied)

$$\text{Therefore, } \frac{\delta T}{T} |_{\max} = \frac{2(\rho\delta h + \sigma\delta d)}{h\rho - d\sigma} \quad \dots(9.4)$$

where, $\delta h = \delta d = 2 \times v.c$ of the microscope. Substituting measured values of h , σ we can calculate $\frac{\delta T}{T} |_{\max}$

$$\therefore \text{Maximum percentage error} = \frac{\delta T}{T} |_{\max} \times 100\% = \dots\%$$

Conclusion : Measured value of the surface tension of liquid is accurate within the errors involved in our experimental arrangement.

Key Words : (i) Surface tension (ii) Specific gravity bottle.

(iii) Excess pressure

Summary :

- (i) Surface tension of a liquid (water) has been defined and its measurement by Jaeger's method is discussed. The expression for excess pressure inside a spherical air bubble formed inside a liquid is used to determine surface tension.
- (ii) To find surface tension of a liquid at temperature other than room temperature, the value of $f(r)$ is calculated by using known value of surface tension of the liquid (water) at room temperature and the measured values of h , d , ρ and σ from equation (9.2).

- (iii) Using this value of $f(r)$ and the measured values of h at different temperatures for fixed depth, we have calculate surface tension of experimental liquid (water) at different temperatures, higher than room temperatures using equation (9.1).
- (iv) Drawing $\theta - T$ graph, we can calculate the surface tension of liquid at any temperature provided the temperature lies within the range of temperature observed.
- (v) Precautions have been discussed and the accuracy of measurement is checked.

Model Questions and answers :

1. How does surface tension vary with temperature?

Ans. With the rise of temperature surface tension of a liquid decreases and vanishes at the critical temperature of the liquid. For small range of temperaure, surface tension at $\theta^\circ\text{C}$ is $T_\theta = T_0 (1 - \alpha\theta)$ where $T_0 =$ surface tension at 0°C $\alpha =$ temperature co-efficient of surface tension.

2. What will happen to surface tension if oil or grease is added to a liquid?

Ans. Surface tension will reduce considerably.

3. What will happen if you increase the depth of orifice?

Ans. With the increase of depth of orifice, the manometric level difference (h) will increase.

4. Can water or mercury be used in the manometer?

Ans. No, Due to high density of mercury and water, the difference of liquid levels (h) in the manometer will be very small. So accurate measurement of h will not be possible. Therefore, manometric liquid should be of very low density e. g., Kerosine, Xylol.

5. How is bubble formed?

Ans. When water enters the bottle *W* coming from reservoir *R*, the air above water level in bottle *W* is compressed. When this compressed air enters the tube *C*, it escapes through the orifice in the form of bubbles.

6. On what factors the accuracy of the experiment depend?

Ans. The accuracy of this experiment depends on (i) the narrowness of capillary tube *C* (ii) the precise measurement of manometer reading just at the time of breaking away of the bubble.

Unit - 10A □ Determination of the focal length of a concave lens by combination method

Introduction : We can measure the focal length of a convex lens by displacement method or $u - v$ method. But these methods can not be used to determine the focal length of a concave lens since a concave lens produces only virtual image which can not be cast on a screen. The focal length of a concave lens can be determined by employing any one of the following methods (i) combination method (ii) auxiliary lens method (iii) concave mirror method.

In this unit, the determination of focal length of a concave lens by combination method has been discussed. If a convex lens of shorter focal length is kept in contact coaxially with a concave lens of longer focal length the combination will behave as a converging lens forming real image. We can measure the equivalent focal length of the combination by displacement method. By finding the focal length of convex lens of the combination and equivalent focal length, the focal length of the concave lens can be found out.

Objective : To measure the focal length of a concave lens by combination method.

Theory :

Definition : The focal length of a lens is defined as the image distance when the object distance is infinity i.e., incident rays are parallel.

S.I. unit of focal length is m .

Working formula :

The focal length of a concave lens is given by

$$f_2 = \frac{Ff_1}{F - f_1} \quad \dots (10.1)$$

where, f_1 = focal length of the convex lens of the combination.

F = focal length of the combined lens.

Focal length of a convex lens is given by the relation

$$f = \frac{D^2 - x^2}{4D} \dots (10.2)$$

where, D = distance between the object and the screen which is greater than 4f.

x = distance between two positions of the lens for which it forms sharp images on the screen.

We can find f_1 and F using equation (10.2)

Procedure :

1. Placing the object and the screen on their stands at two extreme ends of the optical bench, reading (a) of the object stand is noted from its index mark and bench scale. The position of the object stand should be kept fixed throughout the experiment.
2. Then index error (λ) between the object and the screen is to be determined. Keeping the index rod between the object and screen stand horizontally, the object and screen are made to touch the two ends of the index rod.
The readings (x) and (y) of the two stands are taken, their difference (d) = $X - Y$ gives the apparent length of the index rod. The length (l) of the index rod is measured by a metre scale. Then index error is $\lambda = l - d$.
3. Now the screen is placed at sufficient distance from the object and a convex lens is placed between the object and the screen. Adjusting the heights of the three stands the centres of object, screen and lens are placed on the same horizontal line.
4. Then the position of the screen is so adjusted that for two different positions of the convex lens which are small distance apart, we get two images—one

magnified and other diminished. Keeping the position of the screen fixed, the reading (b) of the screen stand is noted from its index mark and bench scale. So, the apparent distance between the object and the screen is $D_1 = a \sim b$ and correct distance, $D = D_1 + \lambda$.

5. The convex lens is then placed nearer to the object and its position is adjusted until a sharp magnified image is formed on the screen. The reading of the lens stand is taken. Repeating the process thrice, the mean of these readings (R_1) is calculated. This is known as first position of the lens.
6. Next, the convex lens is kept nearer to the screen and its position is adjusted carefully until a sharp diminished image is formed on the same screen. The position of lens stand called second position is noted. Repeating the operation three times, the mean of the readings (R_2) is found out.
7. So, the displacement of the convex lens is $x = R_1 \sim R_2$. Using the values of x and D , the focal length (f_1) of the convex lens is determined using eq. (10.2)
8. Shifting the position of the screen, the operations (4) to (7) are repeated for atleast three different values of D and x . Then finding three values of f_1 , the mean value of f is determined. This gives the actual value of focal length (f_1) of the convex lens.
9. Now, the concave lens is kept in contact coaxially with the convex lens and the combination is placed between the object and the screen. The focal length (F) of the combination is determined by displacement method in the same manner as adopted for the convex lens.
10. Substituting the values of f_1 , F in equation (10.1), the focal length (f_2) of concave lens is obtained.

(C) Determination of the focal length (F) of the combined lens.**Table-3****[Make a table same as Table-2]****Calculations :**

From equation (10.1), we get

$$f_2 = \frac{F f_1}{F - f_1}$$

Substituting the values of f_1 and F (from table-2 and table-3) in the above expression, the value of f_2 is obtained.

Result :

The focal length of the concave lens

$$f_2 = \dots\dots\dots \text{ cm}$$

Discussions :

1. To make proportional error minimum, the value of D ($D > 4f$) should be adjusted such that x is small.
2. The distance (D) between the object and the screen must be greater than $4f$ to get two real images for two different positions of the lens.
3. No index correction is necessary for x since it is the difference in the readings for two lens positions.
4. The focal length (f_1) of the convex lens must be less than the focal length (f_2) of the concave lens i.e., $f_1 < f_2$ so that lens combination behaves as a converging system producing real image. This is essential to find F .

Maximum proportional error :

The focal length of the concave lens is given by (Equation 10.1)

$$f_2 = \frac{F f_1}{F - f_1}$$

Therefore, the maximum proportional error

$$\frac{\delta f_2}{f_2} \Big|_{\max} = \frac{\delta F}{F} + \frac{\delta f_1}{f_1} + \frac{\delta F + \delta f_1}{F - f_1} \dots\dots\dots(10.3)$$

The right hand side of equation (10.3) can be calculated by using the following expression.

$$\frac{\delta f}{f} \Big|_{\max} = \frac{2D\delta D + 2x\delta x}{D^2 - x^2} + \frac{\delta D}{D} \left(\because f = \frac{D^2 - x^2}{4D} \right)$$

$\delta D = 2$ smallest divisions of bench scale

$\delta x =$ Distance moved by the lens without affecting focussing of the image.

Using, the value of observed quantities, $\frac{\delta f_2}{f_2} \Big|_{\max}$ can be calculated from equation (10.3). F should have higher value than f_1 to reduce the error due to last term of equation (10.3).

$$\therefore \text{Maximum percentage error} = \frac{\delta f_2}{f_2} \Big|_{\max} \times 100\% = \dots\dots\dots\%$$

Conclusion : The measured value of the focal length of the concave lens is accurate within the errors involved in the experimental arrangement.

Key words : (i) Focal length (ii) displacement method (iii) Index error (iv) combination method.

Summary :

- (i) Focal length of a lens is defined and the method of determination of the focal length (f_2) of a concave lens by combination method is discussed.
- (ii) Index error (λ) between the object and the screen is determined in order to find the actual distance (D) between the object and the screen.

- (iii) The focal length (f_1) of a convex lens and the focal length (F) of the combined lens is determined by adopting displacement method using equation (10.2).
- (iv) Substituting the values of f_1 , F in equation (10.1), the focal length (f_2) of concave lens is obtained.
- (v) Precautions for measurement of f_2 is discussed and evaluation of proportional error is mentioned.
- (vi) Accuracy of the measurement is checked.

Model questions and answers :

1. How many focal length a lens has and which one is measured here ? Are these focal lengths equal ?

Ans. A lens has two focal lengths—first and second. First focal length is the object distance when image distance is infinity whereas second focal length is the image distance when object distance is infinity.

In the experiment we are measuring second focal length of the lens. Two focal lengths of the lens will be equal when the lens is surrounded by the same media on both sides.

2. Does the focal length of a lens change with colour?

Ans. Yes. We know that the lens maker's formula for a lens is $\frac{1}{f} = (\mu - 1) \left(\frac{1}{r_1} - \frac{1}{r_2} \right)$

where, μ = Refractive index of the material of lens with respect to the surrounding medium.

r_1, r_2 = Radii of curvature of the two lens surfaces.

f = focal length of the lens.

The relation shows f that decreases with the increase of μ . It is known that refractive index of a medium is greater for violet light than for red light i.e, $\mu_v > \mu_r$. So focal length of a lens is greater for red light than for violet light. Focal length (f) of a lens also changes with curvature r , as r increases f decreases.

3. If it is found that the convex lens is not producing real image for any position of the lens, what is the reason?

Ans. This will happen only when the distance (D) between the object and screen is less than four times focal length (f) of the convex lens i.e., $D < 4f$.

4. Can a concave lens produce real image?

Ans. Yes. A concave lens can produce real image when the refractive index of the surrounding medium is greater than the refractive index of the lens material.

5. When you immerse the lens in water, will its focal lengths be same as before?

Ans. No. The focal length of the lens in water will be almost four times greater than in air.

6. What will happen if the distance (D) between the object and screen is large ?

Ans. If D is large, than the displacement of lens (x) will also be of large value. As a result, we will get very diminished image for one position of lens and highly magnified image for other position of lens. This will cause difficulty in focussing the images sharply.

7. Can you measure the size of the object from this experiment?

Ans. Yes. If I_1 and I_2 be the sizes of the images for two positions of the lens, the size of the object $O = \sqrt{I_1 I_2}$.

8. Is displacement method better than $u - v$ method?

Ans. Yes. In the displacement method, x and D can be measured more accurately, the index correction is necessary only for D and the thickness of the lens is not required.

9. In the combination method, can you use a convex lens of any focal length to measure the focal length of a concave lens?

Ans. No. As a concave lens cannot produce real image, a convex lens of high power i.e., smaller focal length should be combined with the concave lens such that the combination behaves as a converging lens system.

10. Why index correction for x is not considered here?

Ans. We do not measure index error (λ) because the displacement of lens is equal to the displacement of the index mark of the stand carrying the lens.

11. How can you measure the focal length of a convex lens where value is about 75 cm by using an optical bench of length 1.5 m?

Ans. We can measure the focal length (f) of this lens by displacement method since f_1 has high value. At first, you have to measure the focal length of a convex lens by displacement method with value 20-30 cm. Then combining this lens with the unknown lens of focal length (f_2) you measure combined focal lengths.

(F) by displacement method. By using formula, $\frac{1}{F} = \frac{1}{f_1} + \frac{1}{f_2}$

we can find f_2 .

**Unit-10B □ Determination of the focal length of a convex lens
by displacement method**

Introduction : There are different methods for the determination of focal length of a convex lens e.g., plane mirror method, $u - v$ method, displacement method. The displacement method is more reliable than $u - v$ method regarding the determination of focal length of a convex lens.

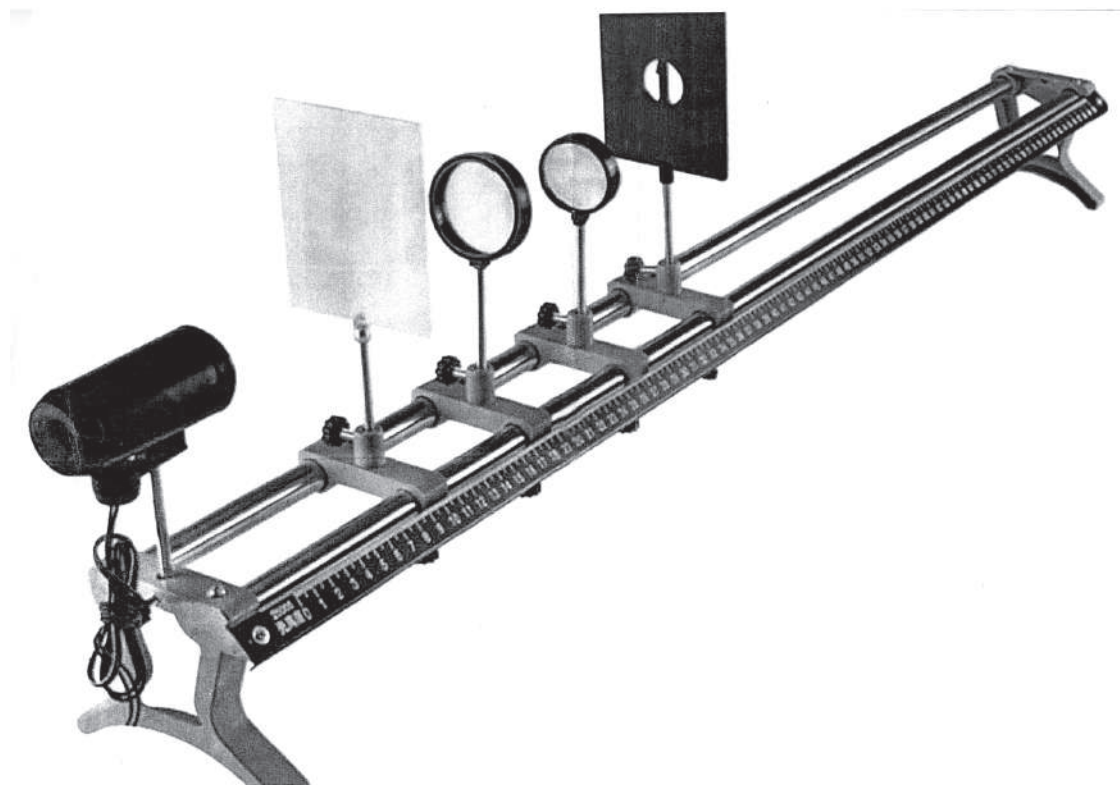

Fig. 10 B.1

Theory :

Working formula : The focal length of a convex lens is given by

$$f = \frac{D^2 - x^2}{4D} \dots (10.2)$$

where, D = distance between the object and the screen which is greater than $4f$.

x = distance between two positions of the lens for which it forms sharp images on the screen.

Procedure :

[Same as 1-8 of unit 10A]

Experimental results :

[Make table-1 and table-2 of unit 10A]

Calculation :

From equation (10.2), we have, $f = \frac{D^2 - x^2}{4D}$

Substituting the values of D , x in the above relation, we get the focal length of convex lens.

Result : The focal length of the given convex lens $f = \dots$ cm

Discussions :

[1 – 3], (same as of unit 10A)

4. We can also find f by drawing a graph with D along X-axis and $\frac{x^2}{D}$ along y-axis. The graph is a straight line. The point where the straight line intersects X-axis has coordinate $(4f, 0)$. Thus $D - 4f = 0$ or, $f = \frac{D}{4}$.

Maximum proportional error :

Focal length of convex lens

$$f = \frac{D^2 - x^2}{4D}$$

∴ Maximum proportional error :

$$\frac{\delta f}{f} \Big|_{\max} = \frac{2D\delta D + 2x\delta x}{D^2 - x^2} + \frac{\delta D}{D}$$

where, $\delta D = 2$ smallest division of bench scale.

$\delta x =$ Distance through which lens can be moved without affecting focusing.

Using set of observed values of D and x , we can calculate the maximum percentage error.

$$= \frac{\delta f}{f} \Big|_{\max} \times 100\% = \dots\dots\dots\%$$

Conclusion : The measured value of the focal length of the convex lens is accurate within the errors involved in the experimental arrangement.

Key words : (i) Focal length, (ii) displacement method, (iii) Index error.

Summary :

- (i) The method of determination of focal length of a convex lens by displacement method is discussed.
- (ii) Index error (λ) between the object and screen is determined to find the actual distance (D) between object and screen.
- (iii) The focal length of convex lens is determined by adopting displacement method finding D , x and using equation (10.2)
- (iv) Precautions for measurement of f is discussed and evaluation of proportional error is mentioned.
- (v) Accuracy of the measurement is checked.

Model questions and answers :

- 1. How many focal length a lens has and which one is measured here ? Are these focal lengths equal ?**

Ans. A lens has two focal lengths—first and second. First focal length is the object distance when image distance is infinity whereas second focal length is the image distance when object distance is infinity.

In the experiment we are measuring second focal length of the lens. Two focal lengths of the lens will be equal when the lens is surrounded by the same media on both sides.

- 2. Does the focal length of a lens change with colour?**

Ans. Yes. We know that the lens maker's formula for a lens is $\frac{1}{f} = (\mu - 1) \left(\frac{1}{r_1} - \frac{1}{r_2} \right)$

where, μ = Refractive index of the material of lens with respect to the surrounding medium.

r_1, r_2 = Radii of curvature of the two lens surfaces.

f = focal length of the lens.

The relation shows f that decreases with the increase of μ . It is known that refractive index of a medium is greater for violet light than for red light i.e., $\mu_v > \mu_r$. So focal length of a lens is greater for red light than for violet light. Focal length (f) of a lens also changes with curvature r , as r increases f decreases.

- 3. If it is found that the convex lens is not producing real image for any position of the lens, what is the reason?**

Ans. This will happen only when the distance (D) between the object and screen is less than four times focal length (f) of the convex lens i.e., $D < 4f$.

- 4. Can a concave lens produce real image?**

Ans. Yes. A concave lens can produce real image when the refractive index of the surrounding medium is greater than the refractive index of the lens material.

5. When you immerse the lens in water, will its focal lengths be same as before?

Ans. No. The focal length of the lens in water will be almost four times greater than in air.

6. What will happen if the distance (D) between the object and screen is large ?

Ans. If D is large, then the displacement of lens (x) will also be of large value. As a result, we will get very diminished image for one position of lens and highly magnified image for other position of lens. This will cause difficulty in focussing the images sharply.

7. Can you measure the size of the object from this experiment?

Ans. Yes. If I_1 and I_2 be the sizes of the images for two positions of the lens, the size of the object $O = \sqrt{I_1 I_2}$.

8. Is displacement method better than $u - v$ method?

Ans. Yes. In the displacement method, x and D can be measured more accurately, the index correction is necessary only for D and the thickness of the lens is not required.

9. In the combination method, can you use a convex lens of any focal length to measure the focal length of a concave lens?

Ans. No. As a concave lens cannot produce real image, a convex lens of high power i.e., smaller focal length should be combined with the concave lens such that the combination behaves as a converging lens system.

10. Why index correction for x is not considered here?

Ans. We do not measure index error (λ) because the displacement of lens is equal to the displacement of the index mark of the stand carrying the lens.

11. How can you measure the focal length of a convex lens where value is about 75 cm by using an optical bench of length 1.5 m?

Ans. We can measure the focal length (f) of this lens by displacement method since f_1 has high value. At first, you have to measure the focal length of a convex

lens by displacement method with value 20-30 cm. Then combining this lens with the unknown lens of focal length (f_2) you measure combined focal lengths.

(F) by displacement method. By using formula, $\frac{1}{F} = \frac{1}{f_1} + \frac{1}{f_2}$

we can find f_2 .

Unit–11 □ Adjust a spectrometer for parallel rays by Schuster's Method and to find out the angle of a prism

Contents : A spectrometer is adjusted for parallel rays by Schuster's method and the angle of a prism is measured.

Introduction : Spectrometer is an indispensable scientific optical instrument used for wide varieties of purposes.

In the laboratory, for the measurement of different optical parameters by a spectrometer, the first thing we require to move the object to infinity and that is achieved by Schuster's method of adjustment of the spectrometer.

Spectrometer is normally used for recording and analysing optical spectra as a method of analysis, for measuring angle of a prism and refractive indices.

(A) Spectrometer : its construction

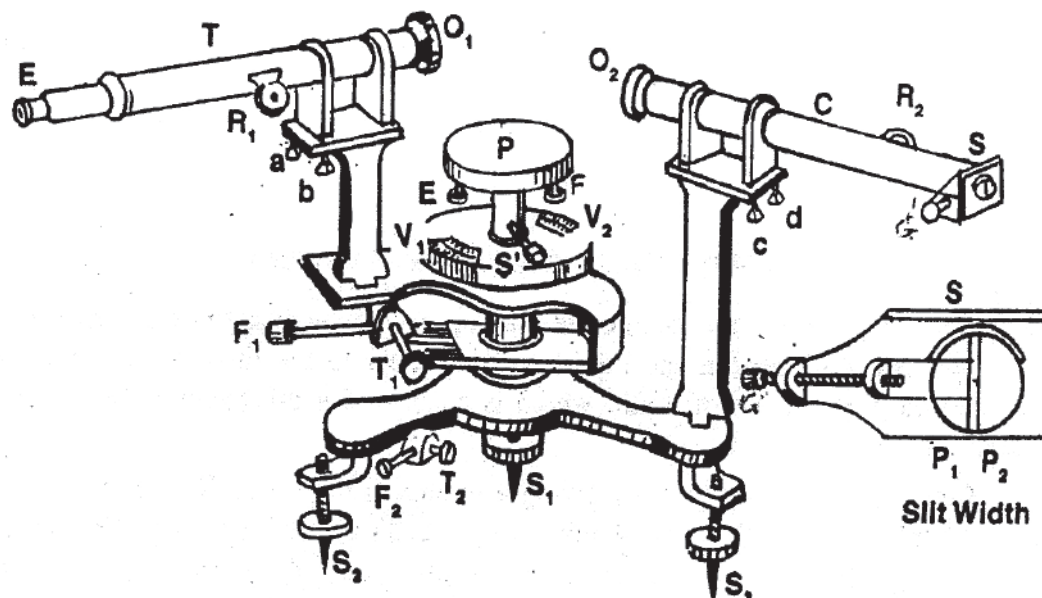

Fig. 11.1

A spectrometer consists of the following parts : (i) prism table (*P*) (ii) collimator (*C*) (iii) Telescope (*T*) (iv) Circular scale (*C.S*)

(1) Prism table (P) :

It is a circular, horizontal plate capable of rotation about the vertical axis of the instrument. It can be fixed at any desired height by screw S^1 . The table can be made horizontal by its three levelling screws E, F, G (fig. 11.1). On the surface of the table, a set of equidistant straight lines are ruled parallel and perpendicular to the line joining screws E and F . A series of concentric circles with the centre of the table as centre are also ruled on the prism table. The table can be rotated about a vertical axis coinciding with the axis of instrument. The angle of rotation can be measured by verniers V_1 and V_2 . The table can be fixed by fixing screw F_2 , a tangent screw T_2 can impart small rotation.

(ii) Collimator (C) :

It is a hollow horizontal tube with achromatic converging lens O_2 at one end and adjustable slit S at the other end. By rack and pinion arrangement R_2 (Fig. 11.1) the distance between the slit and lens can be changed. The axis of the collimator should be horizontal and perpendicular to the vertical axis about which prism table rotates. By means of screws c and d collimator tube is made horizontal.

(iii) Telescope (T)

It is a small astronomical telescope having objective lens O_1 which is an achromatic doublet of concave and convex lens and a Ramsden type eye piece E carrying cross-wires. By adjusting rack and pinion arrangement R_1 , the distance between objective and cross-wires can be changed. The telescope axis can be made horizontal by means of its two screws a and b . The telescope axis should be also horizontal and perpendicular to the vertical axis of rotation of the prism table. The telescope can be rotated about vertical axis and the amount of rotation can be measured by verniers V_1 and V_2 . Telescope is provided with a fixing screw F_1 and tangent screw T_1 . The whole apparatus is supported by levelling screws S_1, S_2 and S_3 (Fig. 11.1)

(iv) The circular scale (C. S) :

A circular scale graduated in degrees is provided with the spectrometer. The scale is rigidly attached to the telescope and turned with its rotation. There are two verniers V_1 and V_2 , 180° apart which rotate over the fixed circular scale with the rotation of the prime table.

(B) Theory of Schuster's method of focussing :

When parallel rays of light coming from an object passes through a prism, the emerging rays appear to come from a point which is the virtual image.

If u = object distance from prism.

v = image distance from prism.

i, r = angle of incidence and angle of refraction at the first refracting surface.

r_1, i_1 = angle of incidence and angle of emergence at second refracting surface.

The relation between u and v is

$$v = \frac{u \left(\frac{\cos^2 i_1}{\cos^2 r_1} \right)}{\left(\frac{\cos^2 i}{\cos^2 r} \right)} \quad \dots \text{ (i)}$$

when prism is at the minimum deviation position (A, B, C), $i = i_1$ and $r = r_1$,
Therefore, at this position $u = v$.

Slant position or slanting position :

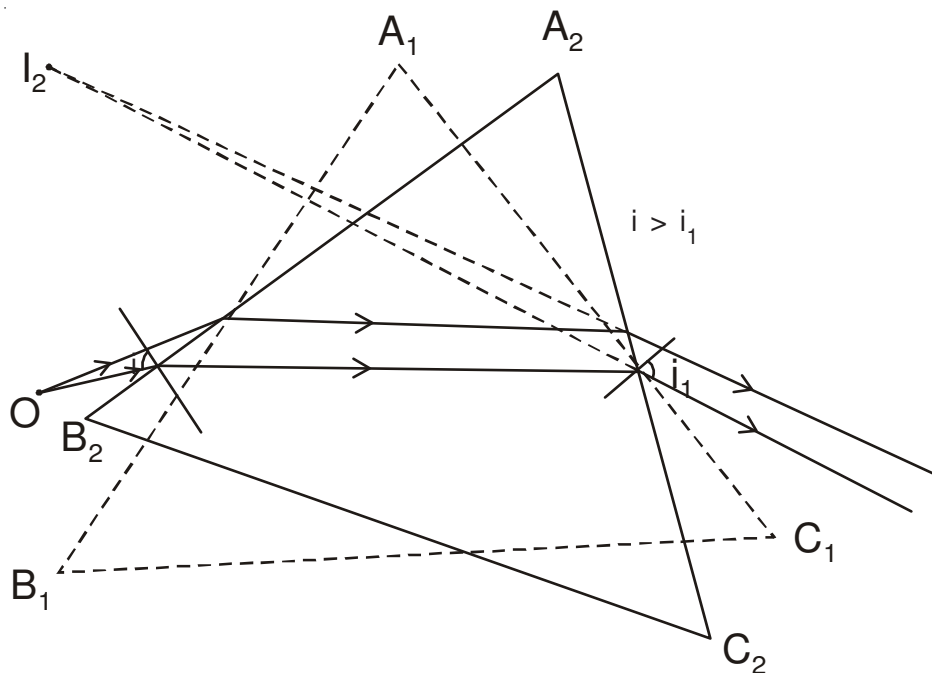

Fig. 11.2 : *Slant position of the prism*

After rotating the prism when the prism is placed at the position $A_2B_2C_2$ (Fig. 11.2), the angle of incidence (i) is greater than that at minimum deviation. This position of prism is called **slant position**. In this case, angle of incidence (i) is greater than angle

of emergence (i_1) and $\frac{\cos^2 i_1}{\cos^2 r_1} > \frac{\cos^2 i}{\cos^2 r}$.

Thus $v > u$ i.e, image (I_2) is formed at longer distance, appears thin and blurred. When image is sharply focussed by rack and pinion arrangement of telescope, image appears very thin. In this case, the telescope is focussed for **longer distance** as image is formed at a longer distance from object.

Normal position :

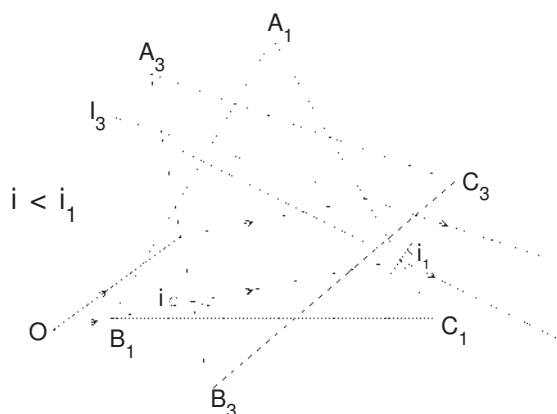

Fig. 11.3 Normal position of the prism

By rotating the prism when prism is taken to the position $A_3B_3C_3$ (Fig. 11.3), the angle of incidence is less than that at minimum deviation. This position of the prism is known as **normal position**. Under this condition, angle of incidence (i) is less than

angle of emergence (i_1) i.e, $i < i_1$ and $\frac{\cos^2 i_1}{\cos^2 r_1} < \frac{\cos^2 i}{\cos^2 r}$.

Thus, $v < u$, image (I_3) is formed nearer to the prism than object (Fig. 11.3). Slit image, in this case, appears broad and blurred. By turning the focussing screw R_2 of the collimator, the image is made sharp, distinct but broad in size. By this adjustment image is taken to a **longer distance**.

Again the prism is rotated in the opposite direction and taken to the slant position,

the image appears thin and goes out of focus. By using screw R_1 , the image is focussed by telescope which is formed at still more longer distance.

The above operations are repeated several times alternately till the image is sharp for both the positions of the prism. For each normal position of the prism, by adjusting collimator the image is taken to a longer distance which was already focussed by telescope for longer distance. During focussing of image for next slant position, image is formed at still more longer distance. In this way, after few repeated operations, the telescope will be focussed for infinity i.e, image is formed at infinity. Now the **spectrometer is focussed for parallel rays and the telescope and collimator are adjusted for parallel rays.**

Objective : We intend to discuss the method of adjustment of a spectrometer for parallel rays by Schuster's method and to find the angle of a prism.

Theory :

(A) Schuster's method of focussing for parallel rays

[See above]

(B) Principle of measurement of the angle of a prism (A)

When parallel rays coming from the a source is incident equally on the two refracting surfaces of a prism, the angle between these two reflected rays (θ) is equal to twice the angle of prism (A) i.e, $\theta = 2A$

$$\text{or, } A = \frac{\theta}{2}$$

Procedure :

1. Adjustment of the spectrometer

Before starting the experimental work with a spectrometer, the following

adjustments are to be performed in the given order :

- (i) Levelling of the telescope, collimeter and prism table.
- (ii) Alignment of the source and slit.
- (iii) Focussing of the cross-wire of eye piece of telescope
- (iv) Adjustment of the slit.
- (v) Focussing for parallel rays : Schuster's method.

(i) (A) Levelling of the telescope :

- (a) After placing a spirit level along the length of telescope, it is made parallel to the line joining base screws S_1 and S_2 (Fig. 8.1). Keeping by the side of S_2 if the bubble of spirit level is not at the centre, it is brought there halfway towards centre by turning the two screws S_1 , S_2 in the opposite directions by equal amount. For other half, the screws (a, b) below telescope is used to take bubble at the centre.
- (b) The telescope is now turned through 180° and placed parallel to the first position. If the bubble is not at the centre, it is taken to the centre by the above process.

The above operations (a) and (b) should be repeated several times until the bubble remains at the centre for both positions.

- (c) Next, the telescope is placed in line with collimator i.e., perpendicular to the line joining levelling screws S_1 and S_2 . The bubble of the spirit level, if displaced, is brought to the centre by turning S_3 screw alone. (If there is no third screw S_3 , screws S_1 and S_2 should be used to bring bubble at the centre.)

When the bubble of spirit level remains at the centre for all positions of the telescope, then **telescope axis is said to be horizontal and its rotation axis is said to be vertical.**

(B) Levelling of Collimator :

Placing a spirit level along the length of a collimator tube, the bubble is brought at the centre by turning the screws c and d below the collimator.

(C) Levelling of prism table :

The spirit level is placed at the centre of prism table being parallel to the line EF, joining its two levelling screws E and F. The bubble is now taken to the centre by turning E and F equally in opposite directions. Now the spirit level is kept perpendicular to EF line and third screw is rotated to bring the bubble at the centre. This adjustment **makes the top of the prism table horizontal.**

(ii) Alignment of the source and the slit.

To make the slit image clear and bright during observation through collimator and telescope, the brightest portion of the source is to be placed in front of the slit. The slit should be kept vertical.

(iii) Focussing of the cross-wire of eye-piece of telescope :

After turning the telescope towards the illuminated slit, the cross-wires of the eye piece is observed. If cross-wires are not clear, the eye piece is adjusted to make the cross-wires distinct.

(iv) Adjustment of the slit :

After making alignment of the slit, the telescope is placed in line with the collimator and image of the slit is observed. By turning the focussing screw of the telescope and collimator, the image is made sharp. The image of slit is made vertical by turning the slit.

The width of the slit is adjusted by screw G_1 so that it is very small (1 or 2 mm) and boundary edges of the slit are sharply defined.

(v) Focussing for parallel rays : Schuster's method

Schuster's method is the best method of focussing the telescope and collimator for parallel rays in a dark room. [consult unit 8(B), chap-1]

2. Measurements

- (i) The vernier constant of the circular scale is determined.
- (ii) The prism is to be placed on the prism table with its apex coinciding with the centre of the prism table and pointing towards the collimator. The refracting surfaces should be equally inclined with the parallel rays coming from the collimator.
- (iii) Clamping the prism table by fixing screw S' (Fig. 11.1), the slit is illuminated by sodium vapour lamp or other source.
- (iv) Now rotating the telescope, it is placed at a position to receive image of the slit formed by reflection from one face of prism. By using the tangent screw the telescope is slowly rotated until the centre of cross-wire coincides with one edge (say right) of the image. The readings of the circular and vernier scale are noted. The operation is repeated thrice and mean value (R_1) is calculated separately for two verniers V_1 and V_2 .
- (v) The telescope is then taken to the other side of the prism to receive the image formed by reflection from other face of the prism. Now coinciding the centre of cross-wire with the same edge (right) of slit image, readings of the circular scale and vernier scales are noted. The readings are taken thrice and their mean value (R_2) is determined. separately for two vernier V_1 and V_2 .

(vi) The difference of the two mean readings ($R_1 \sim R_2 = \theta$) of the same vernier for two position of telescope is determined separately. The mean (θ) of these two differences is calculated. Then the angle of the prism is given

by $A = \frac{\theta}{2}$.

Experimental results :

Determination of the angle (A) of the prism :

Value of one smallest division of the circular scale (s) min. or sec. =

Vernier constant (v.c) of the verniers = $\frac{s}{n}$. where n = number of vernier division
= ... min or sec.

Table-1

No. of obs.	Vernier number	Readings for the first image				Readings for second image				Difference of two mean readings = $\theta = R_1 \sim R_2$	Mean difference (θ) = 2A	Angle of the prism $A = \frac{\theta}{2}$
		circular scale (S)	vernier (V) = $v.r \times v.c$	Total $R_1 = S + V$	Mean R_1	Circular scale (S)	vernier (V) = $v.r \times v.c$	Total $R_2 = S + V$	Mean R_2			
1.	First (V ₁)				
2.			
3.					
1.	Second (V ₂)
2.			
3.					

Calculation :

The angle of the given prism $A = \frac{\theta}{2} =$

Substituting the value of θ in the above expression,
we get the value of A.

Result : The angle of the given prism

A = degree min sec

Discussions :

1. The source of light must be properly aligned.
2. The slit should be made narrow and illuminated by the brightest portion of the light source.
3. There should not be any parallax between the cross-wires and the slit image.
4. During rotation of the telescope, sometimes vernier zero crosses the zero mark of the circular scale, then angle rotated = $360^\circ -$ (difference of two vernier readings)
5. While determining the angle of the prism, the vertical axis passing through the apex of the prism must pass through the centre of the prism table.
6. During measurement of the angle (θ), one particular end of the slit image must be focussed all times.
7. While using the tangent screw, the telescope or the prism table should be clamped before hand by the fixing screws.

Maximum proportional error :

We know, $A = \frac{\theta}{2}$

\therefore Maximum proportional error = $\frac{\delta A}{A} \Big|_{\max} = \frac{\delta \theta}{\theta}$

where $\delta \theta = 2$ divisions of v. c. of vernier scale.

$$\therefore \text{Maximum percentage error} = \frac{\delta A}{A} |_{\max} \times 100\% = \dots\dots\%$$

Conclusion : Measured value of the angle of the prism is accurate within the errors involved in the experimental arrangement.

Key words : (i) Angle of the prism (ii) Spectrometer (iii) Schuster's method of focussing.

Summary :

- (i) Adjustment of a spectrometer for parallel rays by Schuster's method and measurement of the angle of a prism is discussed in details.
- (ii) Levelling of telescope, collimator and prism table have been made carefully.
- (iii) Alignment of source or slit are also made properly, slit is adjusted and cross wires of eye piece are focussed.
- (iv) By Schuster's method the spectrometer is focussed for parallel rays.
- (v) Angle of the prism is measured carefully by observing the image of the slit by telescope formed by reflection from two refracting surfaces of the prism.
- (vi) Precautions and sources of error are discussed.
- (vii) Accuracy of measurement is checked.

Model questions and answers :

1. Why is instruments levelled ?

Ans. The instrument is levelled to ensure that position of the image will not change with the change of position of the telescope.

2. Why are telescope and collimator focussed for parallel rays?

Ans. If the incident rays are not parallel but diverging or converging, the distance of the image of slit will vary with the change of position of the prism.

As a result, if image is focussed for one position of the prism, it will be out of focus in other positions.

When the telescope and collimator are focussed for parallel rays, both the object and image will be at infinity. In this position when telescope focusses the image, the image will be in focus for all positions of the prism.

3. What type of eyepiece is there in the telescope?

Ans. Ramsden's type of eye piece is used as cross wires are provided for this type of eye-piece.

4. Can you use white light in this experiment?

Ans. No. White light contains seven wavelengths, so each colour will produce an image of the slit. This will make experiment difficult for measurement.

5. What is monochromatic light ? Do you consider sodium light strictly monochromatic?

Ans. Light having a particular wavelength is called monochromatic light. Sodium light is not strictly monochromatic, it contains light of two wavelengths of values 5890\AA and 5896\AA .

6. What kind of image is produced by the telescope?

Ans. The telescope produces virtual image at infinity. The objective of telescope produces a real diminished image while the eye piece produced magnified virtual image.

7. What is there inside a collimator?

Ans. At one end of the collimator tube there is an achromatic converging lens and at the other end there is an adjustable slit.

8. Can you expect an emergent ray for any incident ray on the prism?

Ans. No. There is a certain range of the angle of incidence for a prism of definite angle (A) within which emergent rays are obtained.

Unit-12 □ To determine an unknown low resistance using Potentiometer

Contents : Value of low resistance is measured in line with Principle of Potentiometer.

Introduction : We have learned from Ohm's law how to measure resistance. However, Ohm's law need not be obeyed by passive or active circuit elements in an electrical network whose resistance is required to be measured. This is the marvel of ohm's law, which tells us that if you know the potential drop (V) across a conductor and the current (I) through it, you can measure its resistance (R) ; where $R = \frac{V}{I}$

Potentiometer

(i) **Description :** [Consult Ref. 1]

(ii) **Working Principle**

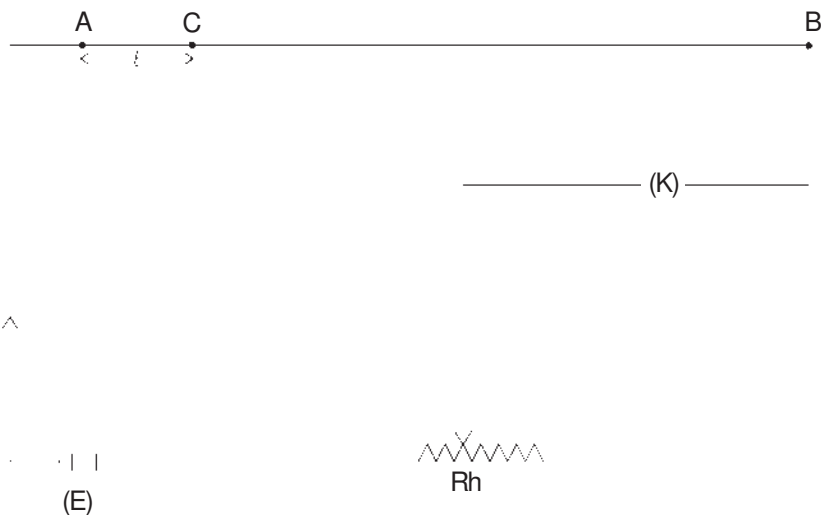

Fig. 12.1

Let, $AB \rightarrow$ the potentiometer wire through which a steady current is passed by means of *D.C.* source (battery of fixed e. m. f)

$I \rightarrow$ current passing through wire AB

$AB = L = 1000 \text{ cm} \rightarrow$ length of the potentiometer wire

$\sigma \rightarrow$ resistance per unit length of the potentiometer wire

\therefore Terminal potential difference of the wire AB

$$V = L \sigma I \dots (12.1)$$

Potential difference of the wire AC of length l

$$v = l \sigma I \dots (12.2)$$

$$\frac{\text{The terminal potential difference of wire } AB \text{ (V)}}{\text{Potential difference of wire } AC \text{ (v)}} = \frac{L \sigma I}{l \sigma I} = \frac{L}{l} \dots (12.3)$$

Hence, the potential difference of wire AC

$$= v = \frac{l}{L} V = \frac{l}{L} L \sigma I = (\sigma I) l \dots (12.4)$$

$\therefore v \propto l$ when σ and I are constant.

Thus we find that when a steady current passes through the potentiometer, the potential difference across any length of the potentiometer wire is directly proportional to the length. This is the **working principle** of the potentiometer.

(B) Standard low resistance**Fig. 12.2**

It consists of a metal strip or a coil fixed by two binding screws C_1 and C_2 , mounted on an ebonite plate. Current enters through one of them and leaves through the other. These two outer terminals (C_1 , C_2) are called **current leads or terminals** (Fig.12.2).

There are two inner terminals or leads (P_1 , P_2) which are connected to definite points X , Y of the low resistance are called **potential leads or terminals** (Fig. 12.2). The value of low resistance (typically less than 1Ω) marked on the ebonite plate is the resistance between these leads (P_1 , P_2) and not between leads C_1 , C_2 . Thus a standard low resistance has **four terminals** or leads.

Objective : We are concerned here to measure a low resistance using principle of potentiometer for with a d. c. source.

Theory :

Definition : Resistance is a property of materials which impede the flow of current through it. Resistances of the order of 1Ω or less are called low resistance in general term. In M. K. S system the unit of resistance is ohm (Ω)

Working formula : The low resistance is given by

$$r = \frac{\rho l}{i} \Omega \dots\dots (12.1)$$

where, l = Length of the potentiometer wire where null point (No deflection of galvanometer) is obtained.

r = A standard low resistance whose value is to be measured.

ρ = Average potential drop per unit length of the potentiometer wire.

ρ is given by

$$\rho = \frac{ER}{L(R + R_p)} \dots\dots(12.2)$$

where, E = E. M. F of the driver storage cell D in potentiometer circuit (Fig. 12.1)

R = Total external resistance in the resistance box R. (Fig. 12.1)

L = Total length of the potentiometer wire usually 10m = 1000 cm.

R_p = Resistance of the potentiometer wire usually supplied by the manufacturer. (see discussion)

Circuit diagram :

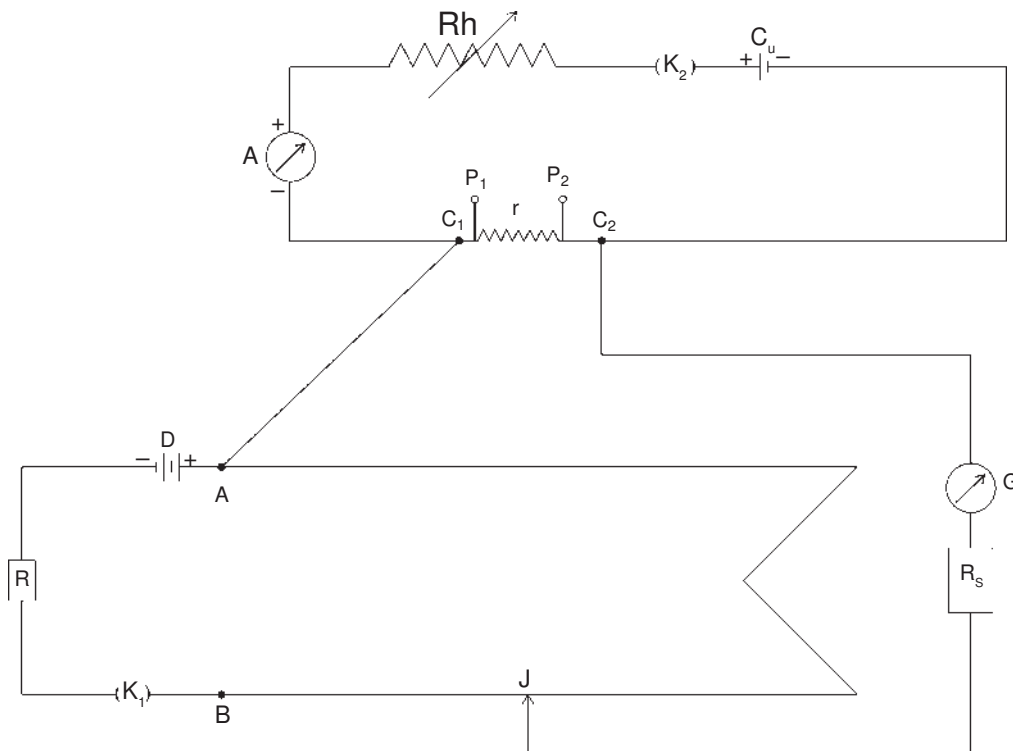

Fig. 12.1

Labelling :

r = Standard low resistance having current leads C_1, C_2 and potential leads P_1, P_2 (see discussion)

C_u = A cell in unknown low resistance circuit.

A = Milliammeter to measure current in mA

K_1, K_2 = Two plug keys (see discussion)

R_h = Rheostat

R = Resistance box in Potentiometer circuit.

D = Driver cell in Potentiometer circuit.

G = Table Galvanometer, R_s = High resistance box. (see discussion)

J = Movable Jockey.

Procedure :

1. A suitable current (i_1) in milliammeter A is kept constant with the help of rheostat R_h to produce a constant voltage drop across the low resistance r . Key K_2 remains closed.
2. A suitable potential drop per unit length (ρ) is produced in the potentiometer wire by taking a proper value of $R = R_1$ so that null point l_1 is obtained preferably on the 10th wire of the Potentiometer by closing key K_1 (see discussion).
3. The resistance R is now changed to other two values $R = R_2$ and $R = R_3$ to get the null points l_2 and l_3 respectively.
4. The procedures (1), (2), (3) are repeated for other two values of currents i_2 and i_3 in milliammeter A ; in table III and table IV.

Experimental results :

(A) To check the constancy of e. m. f's of the cells C_u and D :

Table-I

	EMF of the storage cells		Remark
	C_u	D	
Before experiment volt volt	
After experiment volt volt	

(B) Determination of null points :

Resistance of the Potentiometer wire (R_p) = ohm (supplied)

Current (i_1) =mA

Table-II

No. of obs.	Resistance in box R in ohm	Position of the null point				ρ in volt/cm (from equation 12.2)	Mean $\rho = \frac{\rho_1 + \rho_2 + \rho_3}{3}$ in volt/cm	Remark
		No. of wire	Scale reading in cm	Total length (l) in cm	Mean (l) in cm			
1.	$R = R_1$ =	10 th	$\rho_1 = \dots$		
2.	$R = R_2$ =	10 th	$\rho_2 = \dots$		
3.	$R = R_3$ =	9 th	$\rho_3 = \dots$		

Calculations :

$$\text{low resistance } (r_1) = \frac{\rho_{\text{mean}} \times l_{\text{mean}}}{i_1} \Omega$$

Tables III and IV are made for other two currents i_2 and i_3 and two other values of r e.g. r_2 and r_3 are calculated by using equation (12.1)

Result : Experimental value of the given low resistance $r = \frac{r_1 + r_2 + r_3}{3} = \dots\dots\dots \text{ohm}$

Discussions :

1. In the potentiometer circuit a tap key instead of a plug key K_1 may be used to avoid unnecessary heating of the potentiometer wire.
2. E. M. F of driver cell D must be greater than the cell C_u in the low resistance circuit.
3. For more accurate work potentials at the potential leads P_1 and P_2 should be measured separately and the difference should be taken as the potential drop across low resistance r . This eliminates the potential drop across the current leads. [see, e.g.-Ref.1]
4. End errors of the potentiometer wire is neglected since the wire is long one.

Maximum proportional error :

From equation (12.1) and (12.2), we get,

$$r = \frac{1}{i} \cdot \frac{ERL}{L(R + R_p)}$$

$$\therefore \text{Maximum proportional error} = \frac{\delta r}{r} \Big|_{\text{max}} = \frac{\delta l}{l}$$

Since E, R, L, R_p, i remains constant for a particular set of the experiment. Here $\delta l = 1$ smallest division of scale and l is taken from the data obtained.

Conclusion : Measured value of r is accurate within the errors involved in our experimental arrangement.

Key words : (i) Low resistance (ii) Potentiometer (iii) Driver cell (iv) End errors.

Summary :

- (i) Low resistance has been defined and measured by means of ohm's law.
- (ii) A current i is kept constant to produce a constant potential drop in r .
- (iii) This potential drop in r is measured by the principle of potentiometer.
- (iv) Accuracy of measurement is checked.

Model questions and answers :

1. Why are low resistance provided with four terminals instead of two?

Ans. Consult, unit-12B.

2. Why low resistances are not determined by the Wheatstone bridge method?

Ans. (i) A Wheatstone bridge is sensitive only when the resistance in its four arms are of the same order. (ii) The resistance of the connecting wires are comparable with the low resistance. For these two reasons we cannot measure low resistance by Wheatstone bridge method.

3. Can you compare two very high resistance by this method?

Ans. No. The use of two high resistance will make potentiometer readings very insensitive.

4. What is to be done if null point is not obtained on any of the potentiometer wire?

Ans. To avoid this either resistance R in the potentiometer circuit has to be altered or the current in the low resistance circuit is to be changed.

5. If null point shifts with time, what is your conclusion?

Ans. If null point shifts with time then we should think that either (i) there is heating effect in the potentiometer wire due to continuous flow of current through it which causes increase in its resistance.

or, (ii) the *e. m. f* of the driving cell in the potentiometer circuit is falling continuously.

6. What is the significance of introducing the resistance R_S in series with the galvanometer?

Ans. This high resistance R_S protects galvanometer from being damaged.

7. Do you know any other method of measuring very low resistance?

Ans. Yes, Kelvin's double bridge method may be employed to measure very low resistance.

N. B. Similar Experiment :

Compare two low resistances with the help of a potentiometer and find out one when the other low resistance is known [*see. Ref. 1*]

Unit-13A □ Write a program in C to find sum and average of given number set

Structure/Algorithm :

Step 1 : start the program.

Step 2 : enter the size of the Array (n)

Step 3 : enter the elements of the Array.

Step 4 : set the loop up to array size-1.

Step 5 : Add the array values with S which is initialized by zero.

Step 6 : Calculate average i.e., $avg = [float] s/n$

Step 7 : Calculate average value.

Step 8 : stop.

Objectives

(1) To learn how to implement syntax and semantics of the C programming language.

(2) To learn how to use array values in C programming language.

Code :

```
# include < stdio. h >
```

```
# include < conio. h >
```

```
void main ( )
```

```
{
```



```
int a [30],i,n,s = 0 ;

float avg ;

clrscr ( ) ;

printf(" Enter the limit : ") : ;

scanf("%d", & n) ;

printf (" Enter the value ; ") ;

for (i = 0 ; i < n ; i ++ )

{

scanf ("%d", & a[i]) ;

}

for (i = 0 ; i < n ; i ++ )

{

s = s + a [i] ;

}

avg = (float) s/n ;

printf ("sum = %d", s) :

printf ("\n Average = % f", avg) ;

getch () ;
```

Output :

Enter the limit : 3

Enter the value : 5 12 4

Sum = 21

Average = 7

Key words : Array, Array size, Average

Summary : (1) Implementation of syntax and semantics of the language (C)

(2) Use of array values in the C Programming Language.

Model questions :

- (1) Write a programme to calculate sum of n natural numbers.
- (2) Write a programme to calculate the square root of a given number set.

Unit-13B □ Write a programme in C++ to find sum and average of given number set

Structure/Algorithm :

Step 1 : start the programme.

Step 2 : enter the size of the Array (n)

Step 3 : enter the elements of the Array.

Step 4 : set the loop up to array size-1

Step 5 : Add the array values with S which is initialized by zero.

Step 6 : Calculate average i.e., avg =[float] s/n.

Step 7 : Calculate average value.

Step 8 : Stop.

Objectives :

(1) To learn how to implement syntax and semantics of the C programming language.

(2) To learn how to use array values in C programming language.

C++ Code :

```
# include < stdio.h >
# include < conio.h >
void main ()
{
int a[30], i, n, s = 0 ;
float avg ;
clrscr () ;
cout << "Enter the limit : " ;
cin >> n ;
cout << "Enter the value : " ;
for (i = 0 ; i < n ; i++)
{
cin >> a[i] ;
}
for (i = 0 ; i < n ; i++)
{
```

```
s = s + a [i];  
}  
avg = (float) s/n ;  
cout << "Sum = " << s ;  
cout << "Average" << avg ;  
getch () ;  
}
```

Output :

```
[Enter the limit : 3  
Enter the value : 5 12 4  
Sum = 21  
Average = 7]
```

Key Words : Array, Array size, Average**Summary :** (1) Implementation of Syntax and Semantics of the language. (2) Use of array values in the programming language.**Model questions :**

- (i) Write a programme to calculate sum of n natural numbers.
- (ii) Write a programme to calculation the square roof of a given number set.

Unit-14A □ Write a programme in C to find out largest number and its position in a given number set

Unit-14A**Structure/Algorithm :**

- Step 1 : start the programme.
- Step 2 : Enter the size of the Array (n)
- Step 3 : Enter the Array elements.
- Step 4 : Set Max = array's 1st element i.e., a[0]
- Step 5 : Set the loop from 1 to Arraysize-1
- Step 6 : if MAX < a[i] then
- Step 7 : MAX = a[i]
- Step 8 : set POS = i (index of MAX value)
- Step 9 : end if
- Step 10 : print the largest value i.e, MAX
- Step 11 : print the largest values position, i.e., pos
- Step 12: stop.

Objectives :

By this programme we can learn how to traverse the array elements & find out their position i.e, index of an array element.

To learn how to implement syntax & semantics of the C programming.

C Code :

```
# include <stdio. h >
# include < conio. h >
void main ()
{
int a [30], I, n, max, pos = 0 ;
clrscr () ;
printf {“Enter the limit : ”} ;
scanf (“%d”, & n) ; printf (“Enter the value :”) ;
for (i = 0 ; i < n ; i++)
{
```

```
scanf ("%d", & a[i]) ;
{
max = a [0] ;
for (i = 1 ; i < n ; i++)
{
if (max < a [i])
}
max = a [i] ;
pos = i ;
}
}
printf ("largest value = %d", max) ;
printf ("\n position = %d", pos+1) ;
getch () ;
}
```

Output :

Enter the limit : 3

Enter the value : 5 12 4

largest value = 12

position = 1

Key words : Elements, Srray elements, Do loop.

Summary : (1) Syntax and Semantics of the C Programming Language have been implemented.

(2) Array values have been used.

Model questions :

Write a programme to find out minimum number and its position in a given number set.

Unit-14B □ Write a program in C++ to find out largest number and its position in a given number set

Structure/Algorithm :

- Step 1 : start the program.
- Step 2 : Enter the size of the Array (n)
- Step 3 : Enter the Array elements.
- Step 4 : set Max = array's 1st element i.e. a[0]
- Step 5 : Set the loop from 1 to Array size-1
- Step 6 : if Max < a[i] then
- Step 7 : Max = a[i]
- Step 8 : Set POS = i (index of MAX value)
- Step 9 : end if.
- Step 10 : print the largest value i.e. MAX.
- Step 11 : print the largest values position. i.e.; pos
- Step 12 : stop.

Objectives

By this program we can learn how to traverse the array elements & find out their position i.e., index of an array element.

To learn how to implement syntax & semantics of the C programming

C++ Code :

```
# include < stdio. h>
# include<conio.h>
void main ()
{
    int a [30], I. n, max, pos = 0 ;
    clrscr () ;
    cout << "Enter the limit. : " ;
    cin >> n ;
    cout << "Enter the value : " ;
    for (i = 0 ; i < n ; i++)
```

```
{
    cin >> d[i] ;
}
max = a[0] ;
for (i = 1 ; i < n ; i++)
{
    if (max < a [i])
    {
        max = a [i] ;
        pos = i ;
    }
}
cout << "largest value" << max ;
cout << "position = " << pos+1 ;
getch () ;
}
```

Output :

Enter the limit : 3

Enter the value : 5 12 4

largest value = 12

position = 1

Key words : Elements, Array element, for loop.

Summary : (1) Syntax and semantics of the programming language have been implemented.

(2) Array values have been used.

Model questions :

(1) Write a programme to find out minimum number and its position in a given number set.

Unit-15A □ Write a program to arrange a number in ascending order for given number set by using C

Structure/Algorithm :

Step 1 : Start the program,.

Step 2 : Enter the size of Array.

Step 3 : Enter the elements of Array a [n]

Step 4 : Repeat step 5 to 13 until $i < n - i$ where i is initialized by zero

Step 5 : set $j = 0$

Step 6 : repeat step 7 to 12 until $j < n - i - 1$

Step 7 : if $a [j] > a [j + 1]$ then

Step 8 : set $t = a [i + 1]$

Step 9 : $a [j] = a [j + 1]$

Step 10 : $a [j + 1] = t$

Step 11 : END IF

Step 12 : $j = j + 1$

Step 13 : $i = i + 1$

Step 14 : Print the Array elements.

Step 15 : stop.

Objectives :

By this programme we can learn how to arrange array elements in ascending order which is very helpful for binary search algorithm.

Key words :**C Code :**

```
# include < stdio. h >
```

```
# include < conio h >
```

```
void main ()
```

```
{
```

```
int a[30], i, j, t, n ;
```

```
float avg ;
```

```
clrscr () ;
```

```
printf ("Enter the limit : ") ;
scanf ("%d", &n) ;
printf ("Enter the value : ") ;
for (i = 0 ; i < n ; i++)
{
    scanf ("%d", &a[i]) ;
}
for (i = 0 ; i < n - 1 ; i++)
{
    for (j = 0 ; j < n - i - 1 ; i++)
    {
        if (a[j] >= a [j+ 1])
        {
            t = a[j] ;
            a[j] = a[j + 1] ;
            a [j + 1] = t;
        }
    }
}
printf ("\n After sorting") ;
for (i = 0 ; i < n ; i++)
{
    printf ("%d",a[i] ;
}
getch () ;
}
```

Output :

Enter the limit : 3

Enter the value : 5 12 4

After sorting : 4 5 12

Key words : Array, Ascending order, Decending order, algorithm.

Summary : Arrangement of a Array elements, in ascending order have been done.

Model question : Write a programme to arrange a number in decending order for a given number set.

Unit-15B □ Write a program to arrange a number in ascending order for given number set using C++.

Structure / Algorithm :

Step 1 : Start the program.

Step 2 : Enter the size of Array.

Step 3 : Enter the elements of Array a [n]

Step 4 : Repeat step 5 to 13 until $i < n - i$ where i is initialized by zero

Step 5 : set $j = 0$

Step 6 : repeat step 7 to 12 until $j < n - i - 1$

Step 7 : if $a [j] > a [j + 1]$ then

Step 8 : set $t = a [j + 1]$

Step 9 : $a [j] = a [j + 1]$

Step 10 : $a [j + 1] = t$

Step 11 : END IF

Step 12 : $j = j + 1$

Step 13 : $i = i + 1$

Step 14 : Print the Array elements.

Step 15 : stop.

Objectives

By this program we can learn how to arrange array elements in ascending order which is very helpful for binary search algorithm.

C++ Code :

```
# include < stdio.h >
# include < conio. h >
void main ()
{
    int a[30], i, j, t, n ;
    float avg ;
    clrscr () ;
    cout << "Enter the limit :";
    cin >> n ;
```

```
    cout << "Enter the value :";
    for (i = 0 ; i < n ; i++)
    {
        cin>> a [i] ;
    }
    for (i = 0, i < n - 1 ; i++)
    {
        for (j = 0 ; j < n - i - 1 ; i++)
        {
            if (a [j] >= a[j+1])
            {
                t = a [j] ;
                a [j] = a[j + 1] ;
                a [j +1] = t ;
            }
        }
    }
    {
    cout << " After Sorting" ;
    for (i = 0 ; i < n ; i++)
    {
        cout << a [i];
    }
    getch () ;
    }
```

Output :

Enter the limit : 3

Enter the value : 5 12 4

After Sorting

4 5 12

Key words : Array, Ascending order, Descending order, Algorithm.

Summary : Arrangement of Array elements in ascending order have been done.

Model question : Write a programme to arrange a number in descending order for a given number set.

Suggested Readings

1. Practical Physics — R. K. Shukla, Anchal Srivastava.
2. A text book of Practical Physics — I. Prakash, Ramkrishna
3. Advanced level Practical Physics — M. Nelson, J. M. Ogborn
4. A text book on Practical Physics—K.G. Mazumder.
(for advanced students)
5. A text book of advanced Practical Physics—Samir Kumar Ghosh
6. A text book on Practical Physics—K. G. Mazumder, B. Ghosh.
7. A hand book of Practical Physics—C. R. Dasgupta, S. N. Maiti.
8. Mechanics—D. S. Mathur.
9. An advanced course in Practical Physics—D. Chattopadhyay, P. C. Rakshit.
10. Mechanics and general properties of matter —P. K. Chakraborty.
11. Programming with C by Brian W kernighan and Dennis Ritchie : 2nd Edition.

মানুষের জ্ঞান ও ভাবকে বইয়ের মধ্যে সঞ্চিত করিবার যে একটা প্রচুর সুবিধা আছে, সে কথা কেহই অস্বীকার করিতে পারে না। কিন্তু সেই সুবিধার দ্বারা মনের স্বাভাবিক শক্তিকে একেবারে আচ্ছন্ন করিয়া ফেলিলে বুদ্ধিকে বাবু করিয়া তোলা হয়।

— রবীন্দ্রনাথ ঠাকুর

ভারতের একটা mission আছে, একটা গৌরবময় ভবিষ্যৎ আছে, সেই ভবিষ্যৎ ভারতের উত্তরাধিকারী আমরাই। নূতন ভারতের মুক্তির ইতিহাস আমরাই রচনা করছি এবং করব। এই বিশ্বাস আছে বলেই আমরা সব দুঃখ কষ্ট সহ্য করতে পারি, অস্বকারময় বর্তমানকে অগ্রাহ্য করতে পারি, বাস্তবের নিষ্ঠুর সত্যগুলি আদর্শের কঠিন আঘাতে ধূলিসাৎ করতে পারি।

— সুভাষচন্দ্র বসু

Any system of education which ignores Indian conditions, requirements, history and sociology is too unscientific to commend itself to any rational support.

— **Subhas Chandra Bose**

Price : ₹ 400.00

(Not for sale to the Students of NSOU)